

THIRD EDITION

college
physics a strategic approach

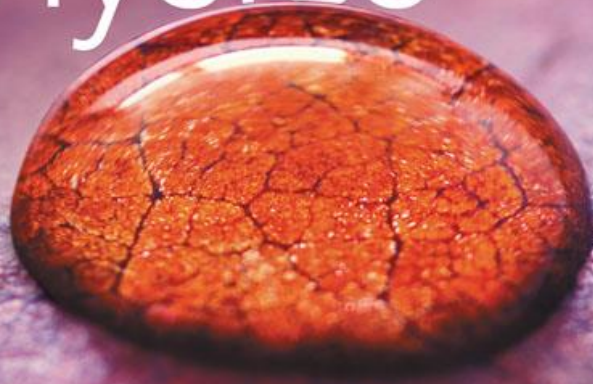

knight · jones · field

Lecture Presentation

Chapter 5

Applying Newton's Laws

Suggested Videos for Chapter 5

- **Prelecture Videos**

- *Static and Dynamic Equilibrium*
- *Weight and Apparent Weight*
- *Friction*

- **Class Videos**

- *Forces in Jumping*
- *Solving Problems Using Newton's Laws*

- **Video Tutor Solutions**

- *Applying Newton's Laws*

Suggested Simulations for Chapter 5

- **ActivPhysics**

- *2.1–2.11*

- **PhETs**

- *Lunar Lander*
- *Forces in 1D*
- *Friction*
- *The Ramp*

Chapter 5 Applying Newton's Laws



Chapter Goal: To use Newton's laws to solve equilibrium and dynamics problems.

Chapter 5 Preview

Looking Ahead: Working with Forces

- In this chapter, you'll learn expressions for the different forces we've seen, and you'll learn how to use them to solve problems.



- You'll learn how a balance between weight and drag forces leads to a maximum speed for a skydiver.

Chapter 5 Preview

Looking Ahead: Equilibrium Problems

- The boy is pushing as hard as he can, but the sofa isn't going anywhere. It's in **equilibrium**—the sum of the forces on it is zero.



- You'll learn to solve equilibrium problems by using the fact that there is no net force.

Chapter 5 Preview

Looking Ahead: Dynamics Problems

- Newton's laws allow us to relate the forces acting on an object to its motion, and so to solve a wide range of **dynamics** problems.



- This skier is picking up speed. You'll see how her acceleration is determined by the forces acting on her.

Chapter 5 Preview

Looking Ahead

Working with Forces

In this chapter you'll learn expressions for the different forces we've seen, and you'll learn how to use them to solve problems.



You'll learn how a balance between weight and drag forces leads to a maximum speed for a skydiver.

Equilibrium Problems

The boy is pushing as hard as he can, but the sofa isn't going anywhere. It's in **equilibrium**—the sum of the forces on it is zero.



You'll learn to solve equilibrium problems by using the fact that there is no net force.

Dynamics Problems

Newton's laws allow us to relate the forces acting on an object to its motion, and so to solve a wide range of **dynamics** problems.



This skier is picking up speed. You'll see how her acceleration is determined by the forces acting on her.

Text p. 125

Chapter 5 Preview

Looking Back: Free-Body Diagrams

- In Section 4.6 you learned to draw a free-body diagram showing the magnitudes and directions of the forces acting on an object.

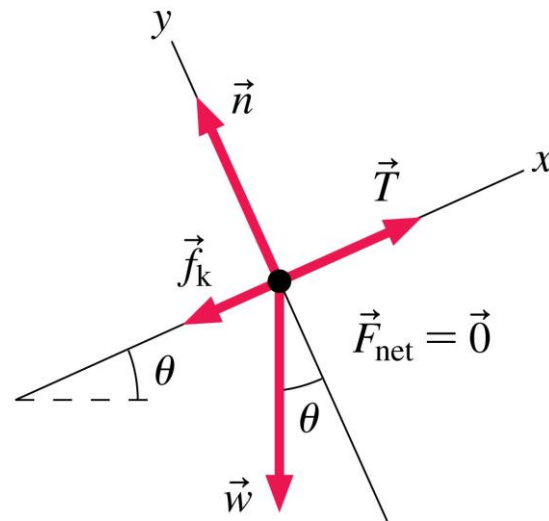

- In this chapter, you'll use free-body diagrams as an essential problem-solving tool for single objects and interacting objects.

Chapter 5 Preview

Stop to Think

An elevator is suspended from a cable. It is moving upward at a steady speed. Which is the correct free-body diagram for this situation?

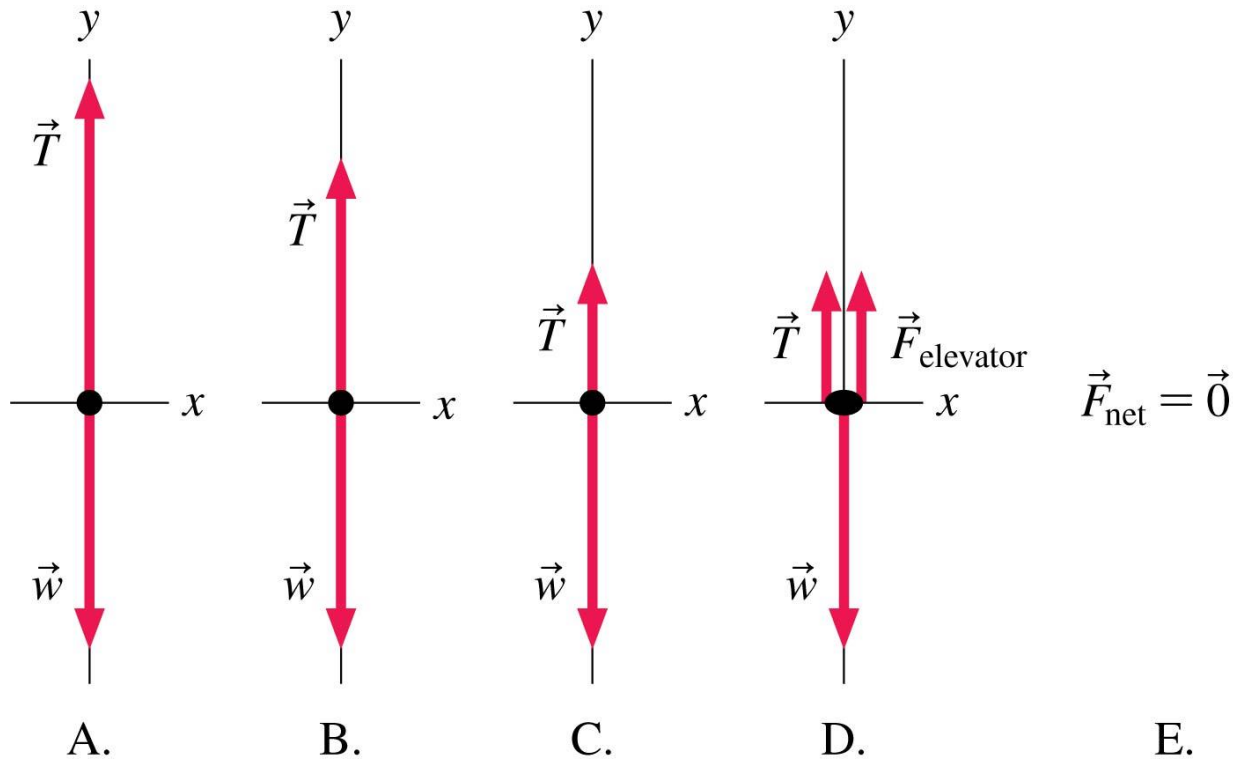

Reading Question 5.1

Which of these objects is in equilibrium?

- A. A car driving down the road at a constant speed
- B. A block sitting at rest on a table
- C. A skydiver falling at a constant speed
- D. All of the above

Reading Question 5.1

Which of these objects is in equilibrium?

- A. A car driving down the road at a constant speed
- B. A block sitting at rest on a table
- C. A skydiver falling at a constant speed

 D. All of the above

Reading Question 5.2

You are riding in an elevator that is accelerating upward. Suppose you stand on a scale. The reading on the scale is

- A. Greater than your true weight.
- B. Equal to your true weight.
- C. Less than your true weight.

Reading Question 5.2

You are riding in an elevator that is accelerating upward. Suppose you stand on a scale. The reading on the scale is

- ✓ A. Greater than your true weight.
- B. Equal to your true weight.
- C. Less than your true weight.

Reading Question 5.3

In general, the coefficient of static friction is

- A. Smaller than the coefficient of kinetic friction.
- B. Equal to the coefficient of kinetic friction.
- C. Greater than the coefficient of kinetic friction.

Reading Question 5.3

In general, the coefficient of static friction is

- A. Smaller than the coefficient of kinetic friction.
- B. Equal to the coefficient of kinetic friction.
- ✓ C. Greater than the coefficient of kinetic friction.

Reading Question 5.4

The drag force pushes opposite your motion as you ride a bicycle. If you double your speed, what happens to the magnitude of the drag force?

- A. The drag force increases.
- B. The drag force stays the same.
- C. The drag force decreases.

Reading Question 5.4

The drag force pushes opposite your motion as you ride a bicycle. If you double your speed, what happens to the magnitude of the drag force?

- ✓ A. The drag force increases.
- B. The drag force stays the same.
- C. The drag force decreases.

Reading Question 5.5

Two boxes are suspended from a rope over a pulley. Each box has weight 50 N. What is the tension in the rope?

- A. 25 N
- B. 50 N
- C. 100 N
- D. 200 N

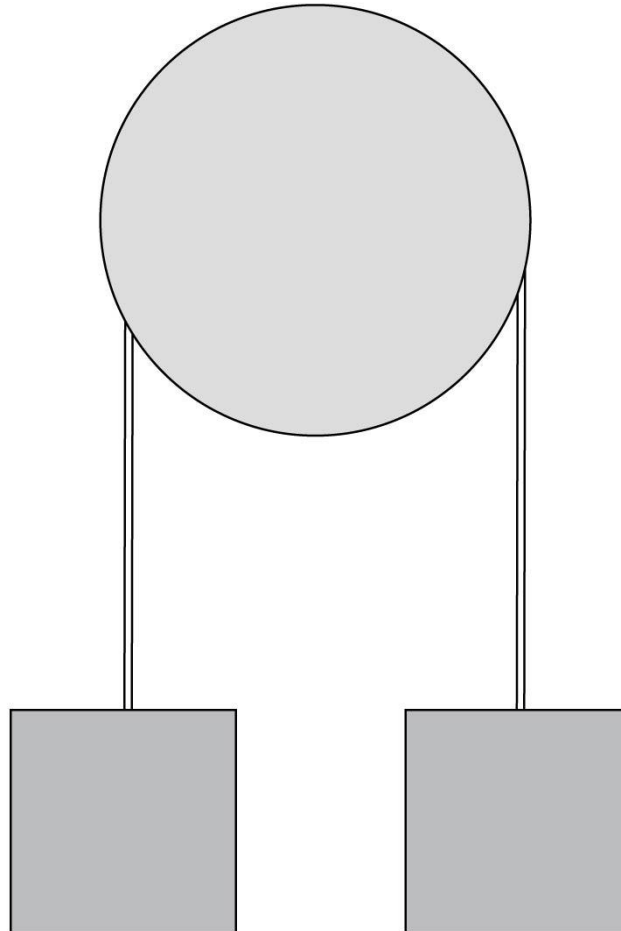

Reading Question 5.5

Two boxes are suspended from a rope over a pulley. Each box has weight 50 N. What is the tension in the rope?

- A. 25 N
- ✓ B. 50 N
- C. 100 N
- D. 200 N

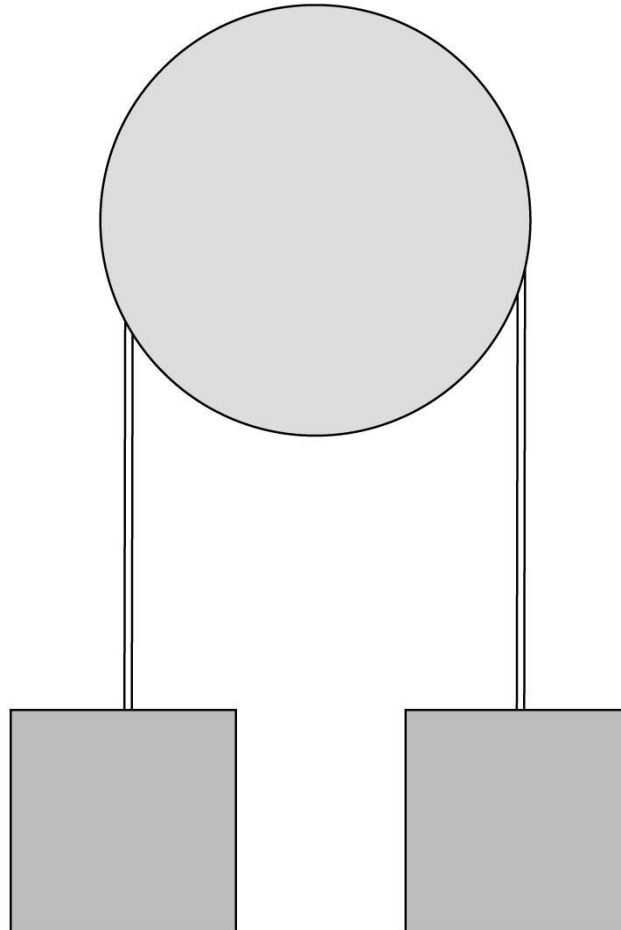

Section 5.1 Equilibrium

Equilibrium

- We say that an object at rest is in **static equilibrium**.
- An object moving in a straight line at a constant speed ($\vec{a} = \vec{0}$) is in **dynamic equilibrium**.
- In both types of equilibrium there is no net force acting on the object:

$$\sum F_x = ma_x = 0 \quad \text{and} \quad \sum F_y = ma_y = 0$$

In equilibrium, the sums of the x- and y-components of the force are zero

Equilibrium

PROBLEM-SOLVING STRATEGY 5.1

Equilibrium problems



If an object is in equilibrium, we can use Newton's second law to find the forces that keep it in equilibrium.

PREPARE First check that the object is in equilibrium: Does $\vec{a} = \vec{0}$?

- An object at rest is in static equilibrium.
- An object moving at a constant velocity is in dynamic equilibrium.

Then identify all forces acting on the object and show them on a free-body diagram. Determine which forces you know and which you need to solve for.

SOLVE An object in equilibrium must satisfy Newton's second law for the case where $\vec{a} = \vec{0}$. In component form, the requirement is

$$\sum F_x = ma_x = 0 \quad \text{and} \quad \sum F_y = ma_y = 0$$

You can find the force components that go into these sums directly from your free-body diagram. From these two equations, solve for the unknown forces in the problem.

ASSESS Check that your result has the correct units, is reasonable, and answers the question.

Text: p. 126

Example 5.1 Forces supporting an orangutan

An orangutan weighing 500 N hangs from a vertical rope. What is the tension in the rope?

Force identification

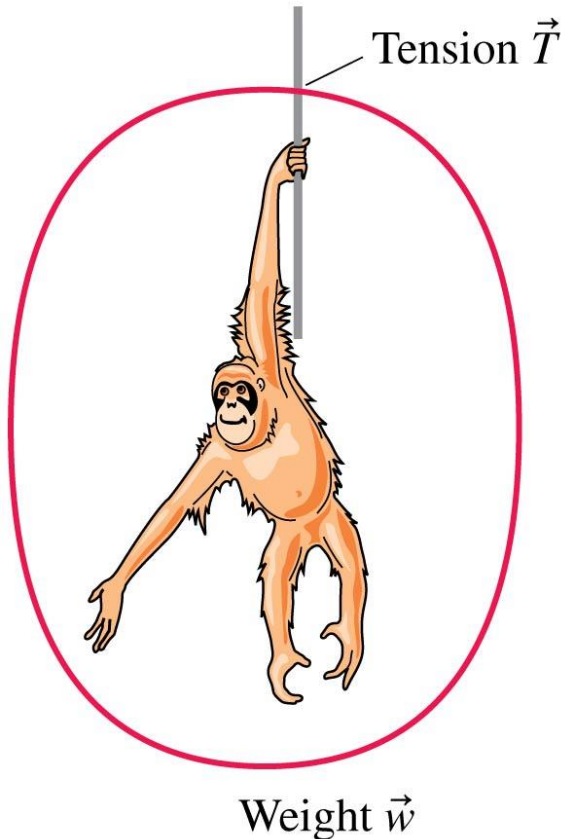

Free-body diagram

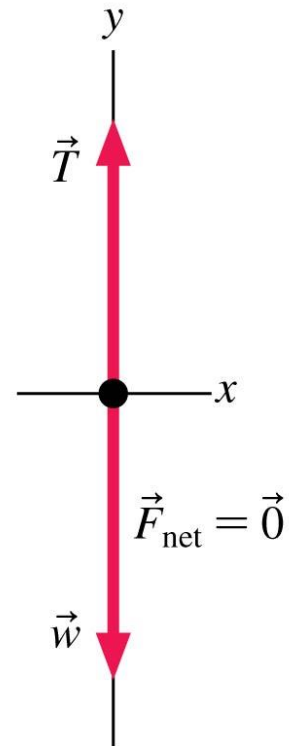

Known

$$w = 500 \text{ N}$$

Find

$$T$$

Example 5.1 Forces supporting an orangutan (cont.)

PREPARE The orangutan is at rest, so it is in static equilibrium. The net force on it must then be zero. FIGURE 5.1 first identifies the forces acting on the orangutan: the upward force of the tension in the rope and the downward, long-range force of gravity. These forces are then shown on a free-body diagram, where it's noted that equilibrium requires $\vec{F}_{\text{net}} = \vec{0}$.

Free-body diagram

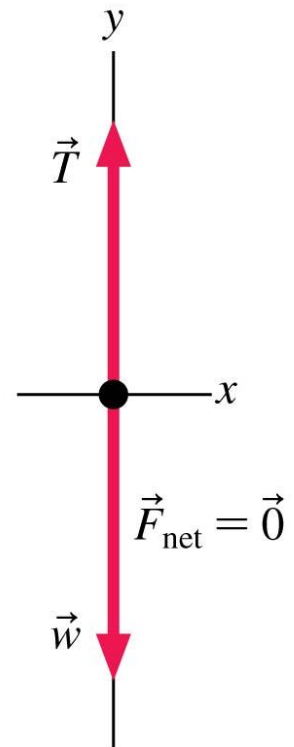

Example 5.1 Forces supporting an orangutan (cont.)

SOLVE Neither force has an x -component, so we need to examine only the y -components of the forces. In this case, the y -component of Newton's second law is

$$\sum F_y = T_y + w_y = ma_y = 0$$

Known
<hr/>
$w = 500 \text{ N}$
Find
<hr/>
T

You might have been tempted to write $T_y - w_y$ because the weight force points down. But remember that T_y and w_y are *components* of vectors and can thus be positive (for a vector such as \vec{T} that points up) or negative (for a vector such as \vec{w} that points down). The fact that \vec{w} points down is taken into account when we *evaluate* the components—that is, when we write them in terms of the *magnitudes* T and w of the vectors \vec{T} and \vec{w} .

Example 5.1 Forces supporting an orangutan (cont.)

Because the tension vector \vec{T} points straight up, in the positive y -direction, its y -component is $T_y = T$. Because the weight vector \vec{w} points straight down, in the negative y -direction, its y -component is $w_y = -w$. This is where the signs enter. With these components, Newton's second law becomes

$$T - w = 0$$

This equation is easily solved for the tension in the rope:

$$T = w = 500 \text{ N}$$

ASSESS It's not surprising that the tension in the rope equals the weight of the orangutan. That gives us confidence in our solution.

Conceptual Example 5.3 Forces in static equilibrium

A rod is free to slide on a frictionless sheet of ice. One end of the rod is lifted by a string. If the rod is at rest, which diagram in FIGURE 5.3 shows the correct angle of the string?

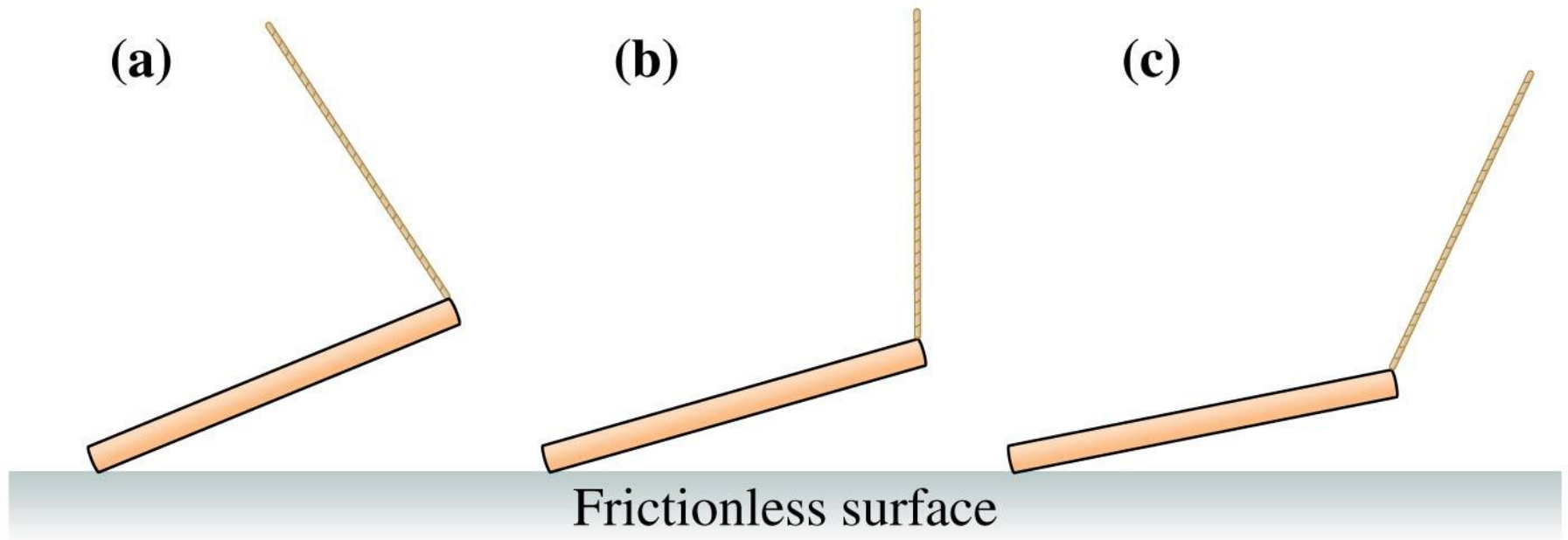

Conceptual Example 5.3 Forces in static equilibrium (cont.)

REASON Let's start by identifying the forces that act on the rod. In addition to the weight force, the string exerts a tension force and the ice exerts an upward normal force. What can we say about these forces? If the rod is to hang motionless, it must be in static equilibrium with $\Sigma F_x = ma_x = 0$ and $\Sigma F_y = ma_y = 0$. FIGURE 5.4 shows free-body diagrams for the three string orientations.

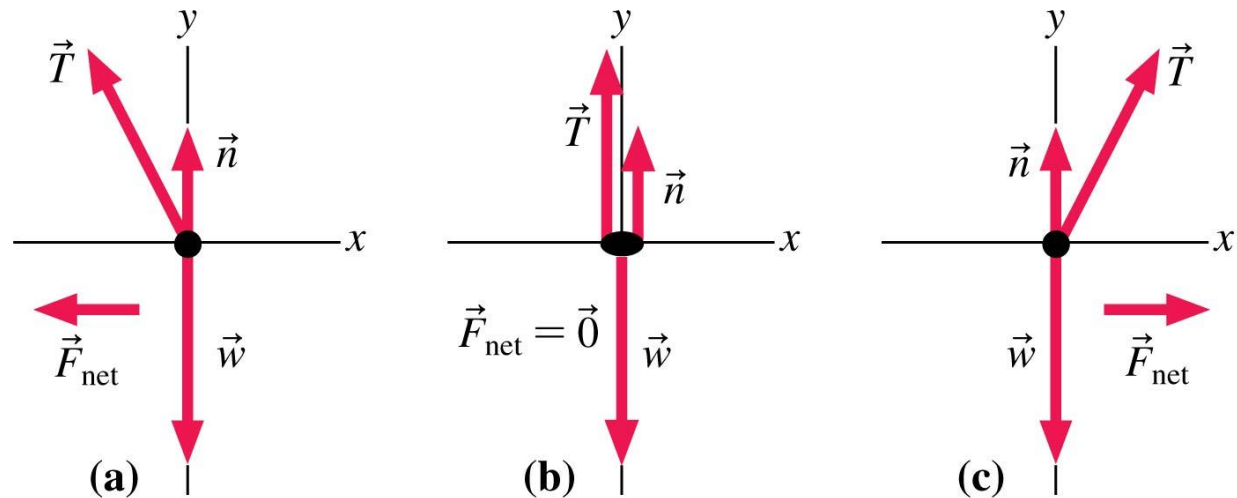

Conceptual Example 5.3 Forces in static equilibrium (cont.)

Remember that tension always acts along the direction of the string and that the weight force always points straight

down. The ice pushes up with a normal force perpendicular to the surface, but frictionless ice cannot exert any horizontal force. If the string is angled, we see that its horizontal component exerts a net force on the rod. Only in case b, where the tension and the string are vertical, can the net force be zero.

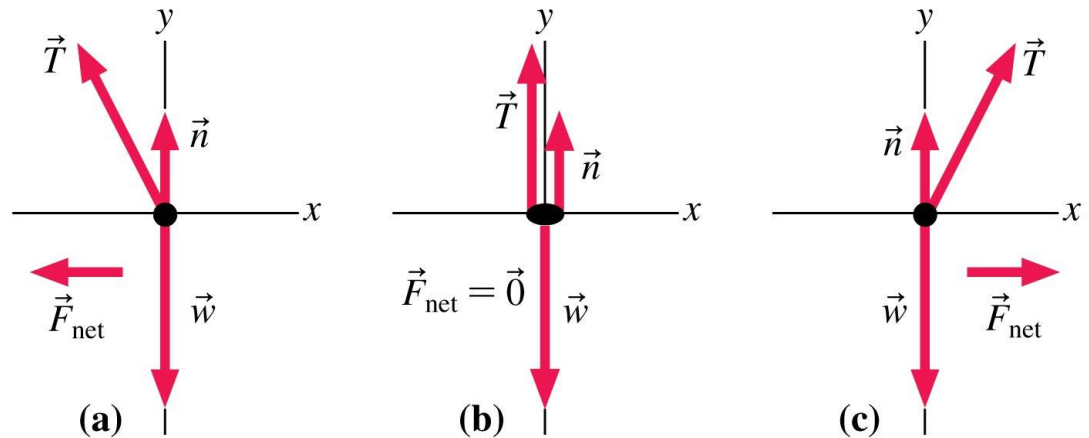

Conceptual Example 5.3 Forces in static equilibrium (cont.)

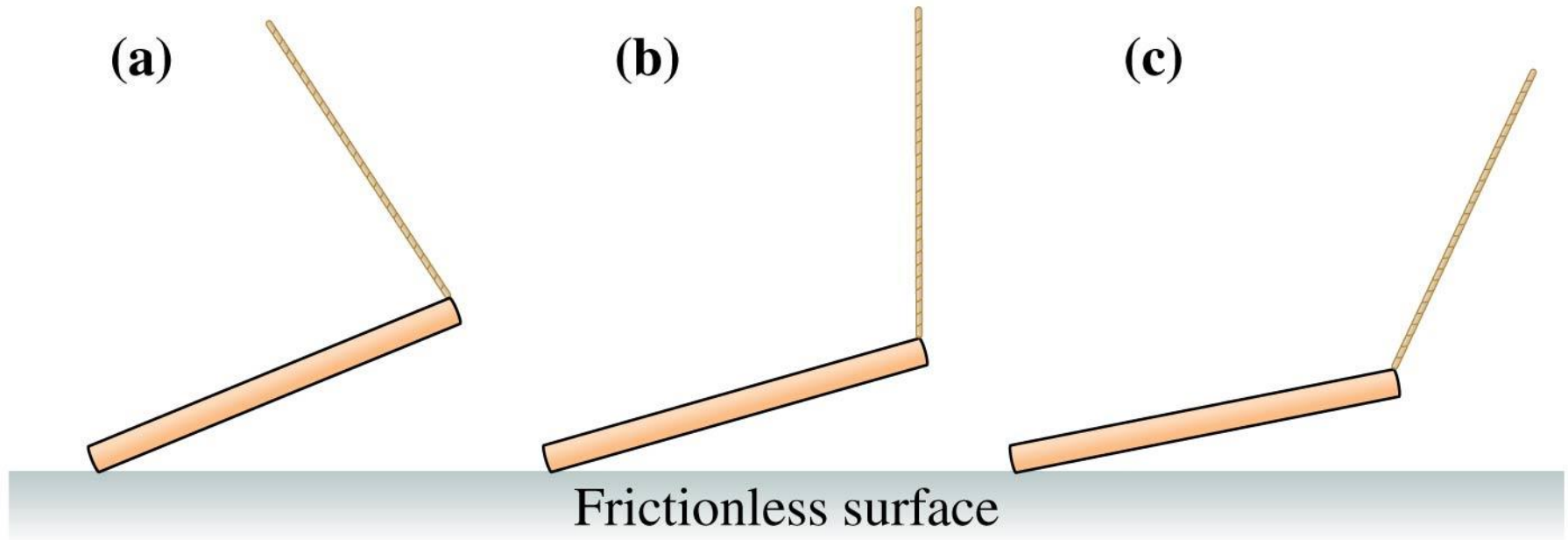

ASSESS If friction were present, the rod could in fact hang as in cases a and c. But without friction, the rods in these cases would slide until they came to rest as in case b.

Example 5.4 Tension in towing a car

A car with a mass of 1500 kg is being towed at a steady speed by a rope held at a 20° angle from the horizontal. A friction force of 320 N opposes the car's motion. What is the tension in the rope?

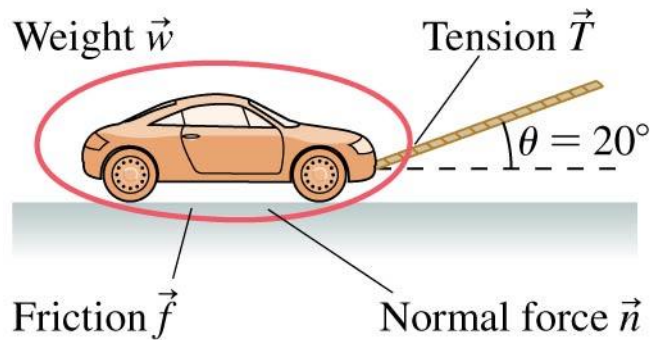

Known

$$\theta = 20^\circ$$

$$m = 1500 \text{ kg}$$

$$f = 320 \text{ N}$$

Find

$$T$$

Example 5.4 Tension in towing a car (cont.)

PREPARE The car is moving in a straight line at a constant speed ($\vec{a} = \vec{0}$) so it is in dynamic equilibrium and must have $\vec{F}_{\text{net}} = m\vec{a} = \vec{0}$. FIGURE 5.5 shows three contact forces acting on the car—the tension force \vec{T} , friction \vec{f} , and the normal force \vec{n} —and the long-range force of gravity \vec{w} . These four forces are shown on the free-body diagram.

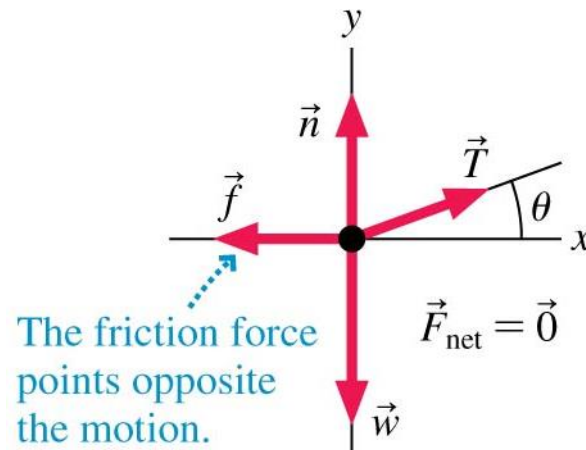

Example 5.4 Tension in towing a car (cont.)

SOLVE This is still an equilibrium problem, even though the car is moving, so our problem-solving procedure is unchanged. With four forces, the requirement of equilibrium is

$$\Sigma F_x = n_x + T_x + f_x + w_x = ma_x = 0$$

$$\Sigma F_y = n_y + T_y + f_y + w_y = ma_y = 0$$

We can again determine the horizontal and vertical components of the forces by “reading” the free-body diagram. The results are shown in the table.

Force	Name of x -component	Value of x -component	Name of y -component	Value of y -component
\vec{n}	n_x	0	n_y	n
\vec{T}	T_x	$T \cos \theta$	T_y	$T \sin \theta$
\vec{f}	f_x	$-f$	f_y	0
\vec{w}	w_x	0	w_y	$-w$

Example 5.4 Tension in towing a car (cont.)

With these components, Newton's second law becomes

$$T \cos \theta - f = 0$$

$$n + T \sin \theta - w = 0$$

The first equation can be used to solve for the tension in the rope:

$$T = \frac{f}{\cos \theta} = \frac{320 \text{ N}}{\cos 20^\circ} = 340 \text{ N}$$

to two significant figures. It turned out that we did not need the y -component equation in this problem. We would need it if we wanted to find the normal force \vec{n} .

Example 5.4 Tension in towing a car (cont.)

ASSESS Had we pulled the car with a horizontal rope, the tension would need to exactly balance the friction force of 320 N. Because we are pulling at an angle, however, part of the tension in the rope pulls *up* on the car instead of in the forward direction. Thus we need a little more tension in the rope when it's at an angle, so our result seems reasonable.

QuickCheck 5.1

A ring, seen from above, is pulled on by three forces. The ring is not moving. How big is the force F ?

- A. 20 N
- B. $10 \cos \theta\text{ N}$
- C. $10 \sin \theta\text{ N}$
- D. $20 \cos \theta\text{ N}$
- E. $20 \sin \theta\text{ N}$

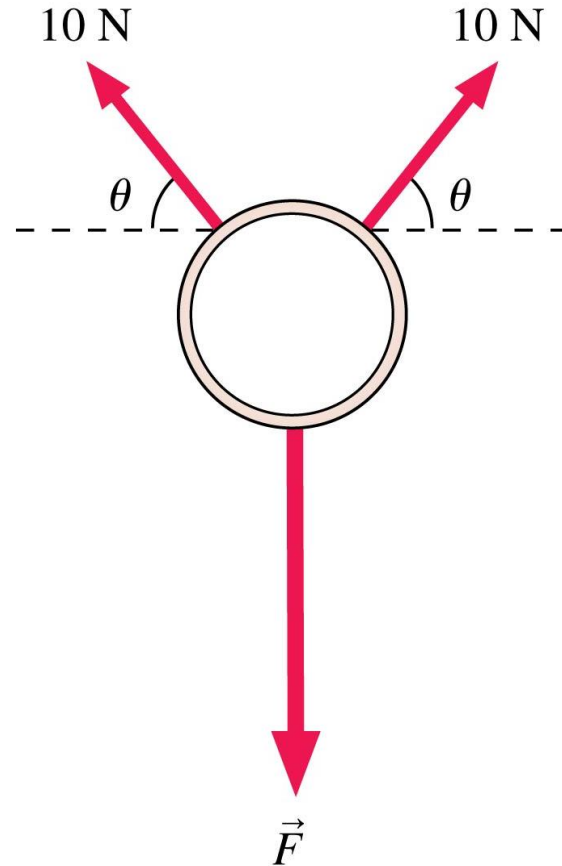

QuickCheck 5.1

A ring, seen from above, is pulled on by three forces. The ring is not moving. How big is the force F ?

- A. 20 N
- B. $10 \cos \theta$ N
- C. $10 \sin \theta$ N
- D. $20 \cos \theta$ N
- ✓ E. $20 \sin \theta$ N

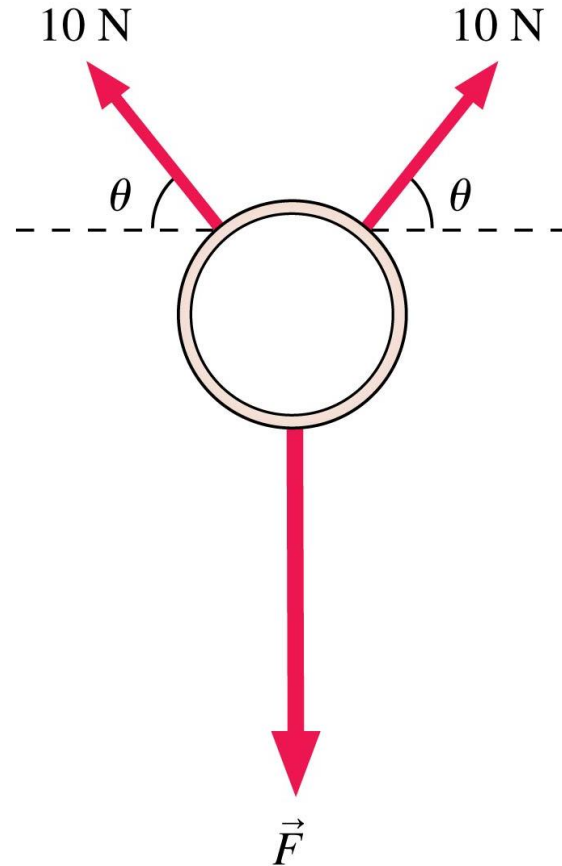

Example Problem

A 100-kg block with a weight of 980 N hangs on a rope. Find the tension in the rope if the block is stationary, then if it's moving upward at a steady speed of 5 m/s.

Section 5.2 Dynamics and Newton's Second Law

Dynamics and Newton's Second Law

- The essence of Newtonian mechanics can be expressed in two steps:
 - The forces acting on an object determine its acceleration
$$\vec{a} = \vec{F}_{\text{net}} / m.$$
 - The object's motion can be found by using \vec{a} in the equations of kinematics.
- Thus Newton's second law, $\vec{F}_{\text{net}} = m\vec{a}$, is

$$\sum F_x = ma_x \quad \text{and} \quad \sum F_y = ma_y$$

Newton's second law in component form

Example 5.5 Putting a golf ball

A golfer putts a 46 g ball with a speed of 3.0 m/s. Friction exerts a 0.020 N retarding force on the ball, slowing it down. Will her putt reach the hole, 10 m away?

PREPARE FIGURE 5.6 is a visual overview of the problem. We've collected the known information, drawn a sketch, and identified what we want to find.



Known		Find
$x_i = 0 \text{ m}$	$f = 0.020 \text{ N}$	x_f
$(v_x)_i = 3.0 \text{ m/s}$	$m = 0.046 \text{ kg}$	
$(v_x)_f = 0 \text{ m/s}$		

Example 5.5 Putting a golf ball (cont.)

The motion diagram shows that the ball is slowing down as it rolls to the right, so the acceleration vector points to the left. Next, we identify the forces acting on the ball and show them on a free-body diagram. Note that the net force points to the left, as it must because the acceleration points to the left.

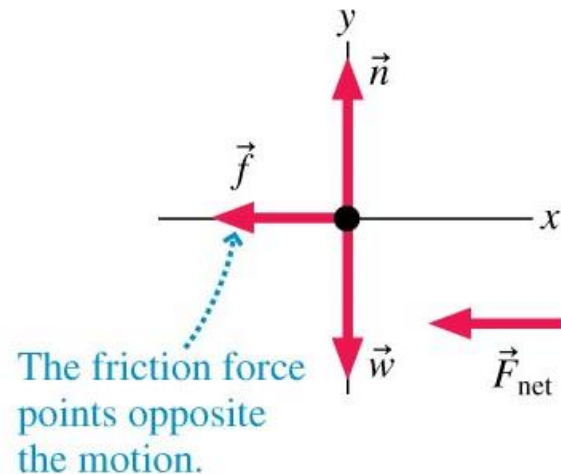
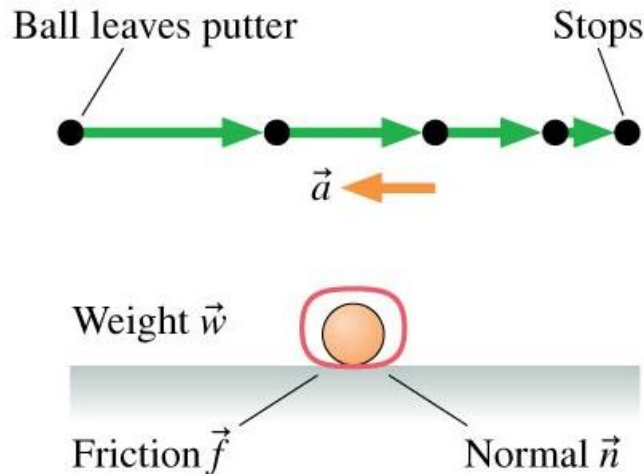

Example 5.5 Putting a golf ball (cont.)

SOLVE Newton's second law in component form is

$$\Sigma F_x = n_x + f_x + w_x = 0 - f + 0 = ma_x$$

$$\Sigma F_y = n_y + f_y + w_y = n + 0 - w = ma_y = 0$$

We've written the equations as sums, as we did with equilibrium problems, then “read” the values of the force components from the free-body diagram. The components are simple enough in this problem that we don't really need to show them in a table. It is particularly important to notice that we set $a_y = 0$ in the second equation. This is because the ball does not move in the y -direction, so it can't have any acceleration in the y -direction. This will be an important step in many problems.

Example 5.5 Putting a golf ball (cont.)

The first equation is $-f = ma_x$, from which we find

$$a_x = -\frac{f}{m} = \frac{-(0.020 \text{ N})}{0.046 \text{ kg}} = -0.435 \text{ m/s}^2$$

To avoid rounding errors we keep an extra digit in this intermediate step in the calculation. The negative sign shows that the acceleration is directed to the left, as expected.

Example 5.5 Putting a golf ball (cont.)

Now that we know the acceleration, we can use kinematics to find how far the ball will roll before stopping. We don't have any information about the time it takes for the ball to stop, so we'll use the kinematic equation

$(v_x)_f^2 = (v_x)_i^2 + 2a_x (x_f - x_i)$. This gives

$$x_f = x_i + \frac{(v_x)_f^2 - (v_x)_i^2}{2a_x} = 0 \text{ m} + \frac{(0 \text{ m/s})^2 - (3.0 \text{ m/s})^2}{2(-0.435 \text{ m/s}^2)} = 10.3 \text{ m}$$

If her aim is true, the ball will just make it into the hole.

Example 5.6 Towing a car with acceleration

A car with a mass of 1500 kg is being towed by a rope held at a 20° angle to the horizontal. A friction force of 320 N opposes the car's motion. What is the tension in the rope if the car goes from rest to 12 m/s in 10 s?

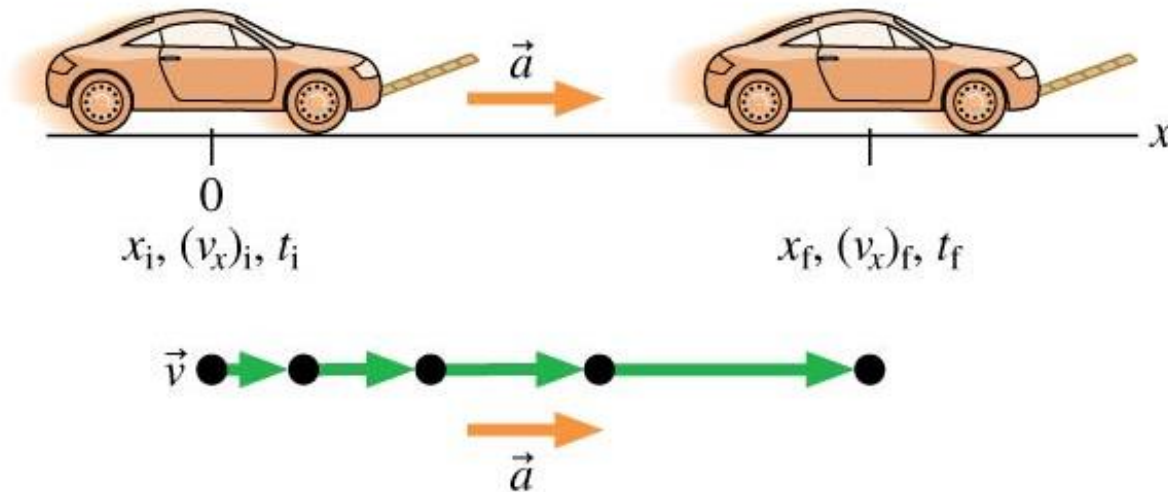

Example 5.6 Towing a car with acceleration (cont.)

PREPARE You should recognize that this problem is almost identical to Example 5.4. The difference is that the car is now accelerating, so it is no longer in equilibrium. This means, as shown in FIGURE 5.7, that the net force is not zero. We've already identified all the forces in Example 5.4.

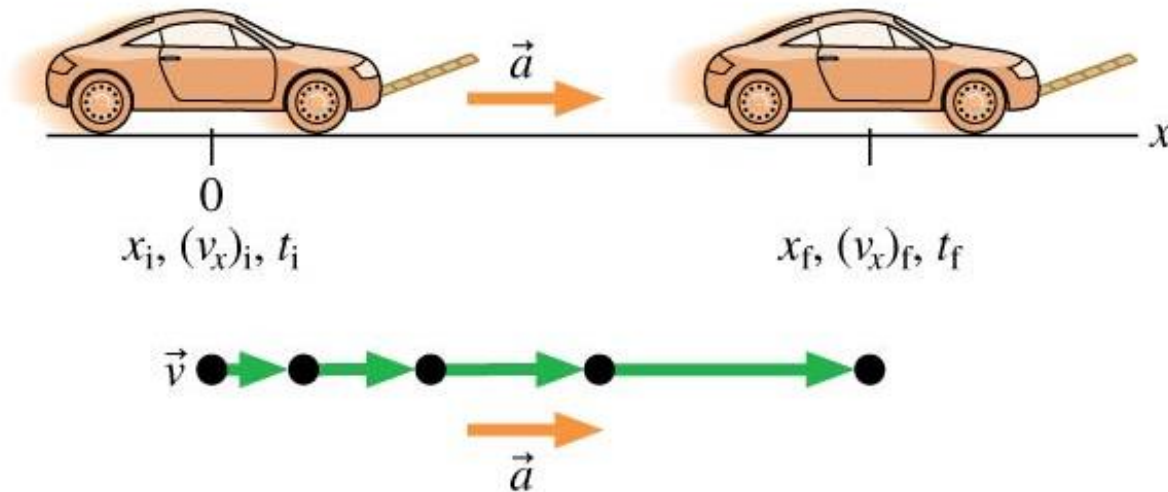

Example 5.6 Towing a car with acceleration (cont.)

Known

- $x_i = 0 \text{ m}$
 $(v_x)_i = 0 \text{ m/s}$
 $t_i = 0 \text{ s}, \theta = 20^\circ$
 $m = 1500 \text{ kg}$
 $f = 320 \text{ N}$
 $(v_x)_f = 12 \text{ m/s}$
 $t_f = 10 \text{ s}$

Find

T

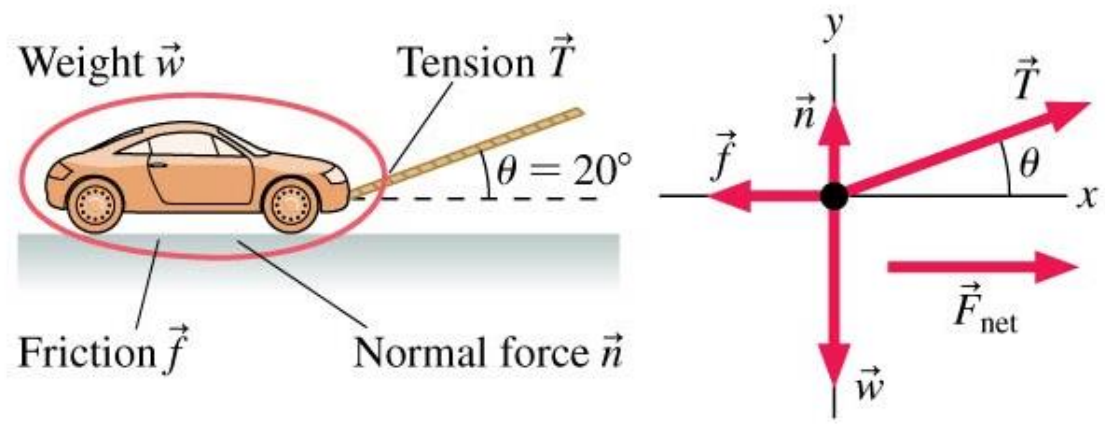

Example 5.6 Towing a car with acceleration (cont.)

SOLVE Newton's second law in component form is

$$\Sigma F_x = n_x + T_x + f_x + w_x = ma_x$$

$$\Sigma F_y = n_y + T_y + f_y + w_y = ma_y = 0$$

We've again used the fact that $a_y = 0$ for motion that is purely along the x -axis. The components of the forces were worked out in Example 5.4. With that information, Newton's second law in component form is

$$T \cos \theta - f = ma_x$$

$$n + T \sin \theta - w = 0$$

Example 5.6 Towing a car with acceleration (cont.)

Because the car speeds up from rest to 12 m/s in 10 s, we can use kinematics to find the acceleration:

$$a_x = \frac{\Delta v_x}{\Delta t} = \frac{(v_x)_f - (v_x)_i}{t_f - t_i} = \frac{(12 \text{ m/s}) - (0 \text{ m/s})}{(10 \text{ s}) - (0 \text{ s})} = 1.2 \text{ m/s}^2$$

Example 5.6 Towing a car with acceleration (cont.)

We can now use the first Newton's-law equation above to solve for the tension. We have

$$T = \frac{ma_x + f}{\cos \theta} = \frac{(1500 \text{ kg})(1.2 \text{ m/s}^2) + 320 \text{ N}}{\cos 20^\circ} = 2300 \text{ N}$$

ASSESS The tension is substantially greater than the 340 N found in Example 5.4. It takes much more force to accelerate the car than to keep it rolling at a constant speed.

Example Problem

A 100-kg block with a weight of 980 N hangs on a rope. Find the tension in the rope if the block is accelerating upwards at 5 m/s^2 .

Example Problem

A ball weighing 50 N is pulled back by a rope by an angle of 20° . What is the tension in the pulling rope?

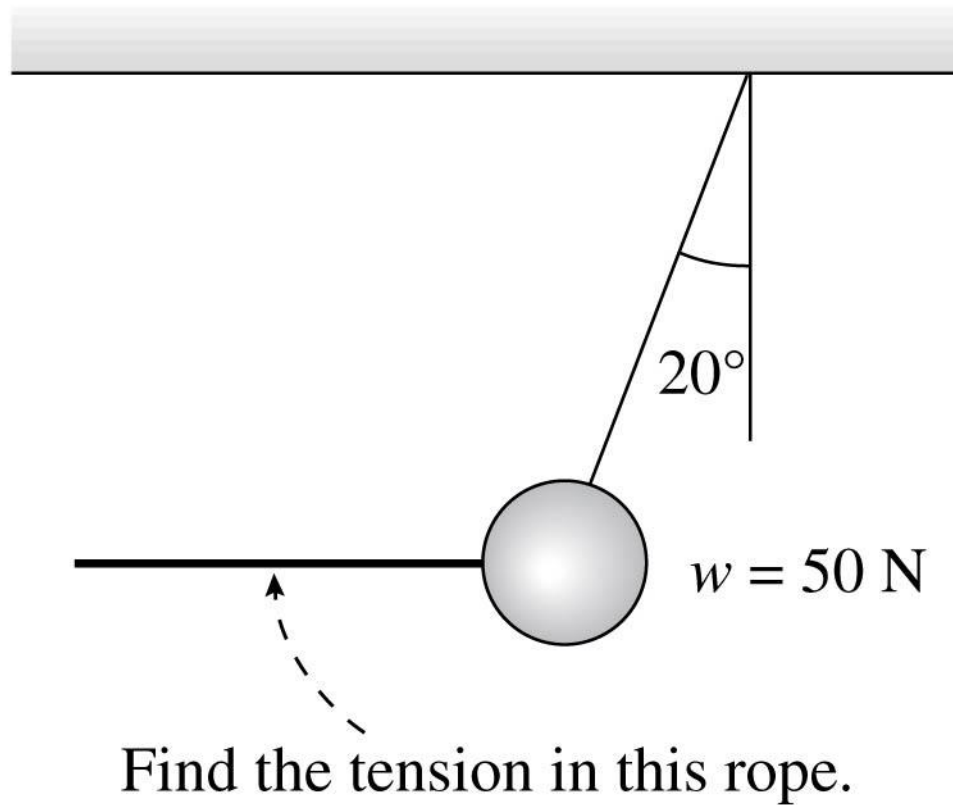

Example Problem

A sled with a mass of 20 kg slides along frictionless ice at 4.5 m/s. It then crosses a rough patch of snow that exerts a friction force of 12 N. How far does it slide on the snow before coming to rest?

Section 5.3 Mass and Weight

Mass and Weight

- **Mass and weight are not the same thing.**
- Mass is a quantity that describes an object's inertia, its tendency to resist being accelerated.
- Weight is the gravitational force exerted on an object by a planet:

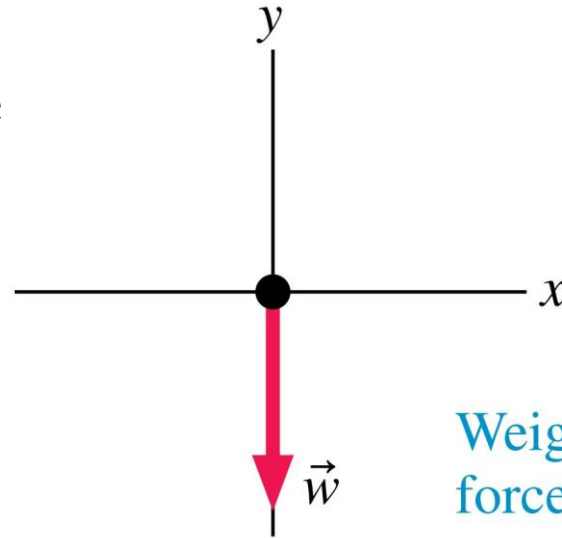

Weight is the only force acting on this object, so $\vec{F}_{\text{net}} = \vec{w}$.

$$w = -mg$$

Mass and Weight

TABLE 5.1 Mass, weight, force

Conversion between force units:

$$1 \text{ pound} = 4.45 \text{ N}$$

$$1 \text{ N} = 0.225 \text{ pound}$$

Correspondence between mass and weight, assuming $g = 9.80 \text{ m/s}^2$:

$$1 \text{ kg} \leftrightarrow 2.20 \text{ lb}$$

$$1 \text{ lb} \leftrightarrow 0.454 \text{ kg} = 454 \text{ g}$$

Example 5.7 Typical masses and weights

What are the weight, in N, and the mass, in kg, of a 90 pound gymnast, a 150 pound professor, and a 240 pound football player?

PREPARE We can use the conversions and correspondences in Table 5.1.

Example 5.7 Typical masses and weights (cont.)

SOLVE We will use the correspondence between mass and weight just as we use the conversion factor between different forces:

$$w_{\text{gymnast}} = 90 \text{ lb} \times \frac{4.45 \text{ N}}{1 \text{ lb}} = 400 \text{ N}$$

$$w_{\text{prof}} = 150 \text{ lb} \times \frac{4.45 \text{ N}}{1 \text{ lb}} = 670 \text{ N}$$

$$w_{\text{player}} = 240 \text{ lb} \times \frac{4.45 \text{ N}}{1 \text{ lb}} = 1070 \text{ N}$$

$$m_{\text{gymnast}} = 90 \text{ lb} \times \frac{0.454 \text{ kg}}{1 \text{ lb}} = 41 \text{ kg}$$

$$m_{\text{prof}} = 150 \text{ lb} \times \frac{0.454 \text{ kg}}{1 \text{ lb}} = 68 \text{ kg}$$

$$m_{\text{player}} = 240 \text{ lb} \times \frac{0.454 \text{ kg}}{1 \text{ lb}} = 110 \text{ kg}$$

Example 5.7 Typical masses and weights (cont.)

ASSESS We can use the information in this problem to assess the results of future problems. If you get an answer of 1000 N, you now know that this is approximately the weight of a football player, which can help with your assessment.

Apparent Weight

- The weight of an object is the force of gravity on that object.
- Your *sensation* of weight is due to *contact forces* supporting you.
- Let's define your **apparent weight** w_{app} in terms of the force you feel:

w_{app} = magnitude of supporting contact forces

Definition of apparent weight

Apparent Weight

- The only forces acting on the man are the upward normal force of the floor and the downward weight force:

$$n = w + ma$$

$$w_{\text{app}} = w + ma$$

- Thus $w_{\text{app}} > w$ and the man feels heavier than normal.

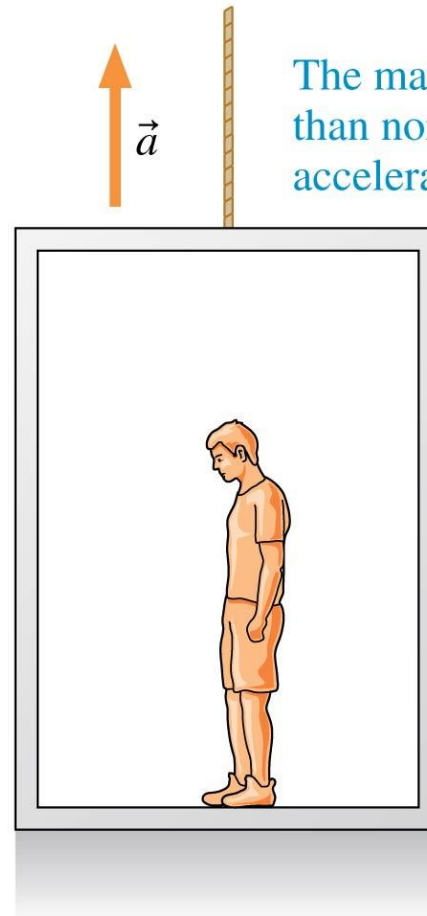

The man feels heavier than normal while accelerating upward.

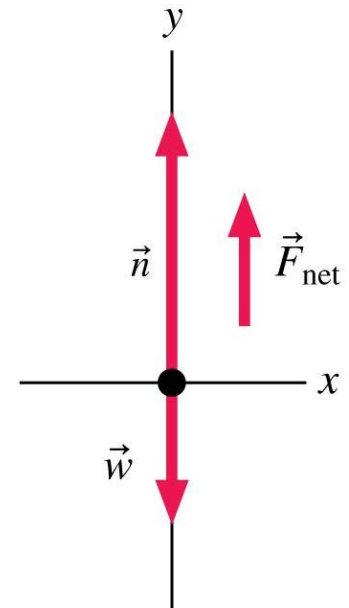

Example 5.8 Apparent weight in an elevator

Anjay's mass is 70 kg. He is standing on a scale in an elevator that is moving at 5.0 m/s. As the elevator stops, the scale reads 750 N. Before it stopped, was the elevator moving up or down? How long did the elevator take to come to rest?

PREPARE The scale reading as the elevator comes to rest, 750 N, is Anjay's *apparent* weight. Anjay's *actual* weight is

$$w = mg = (70 \text{ kg})(9.80 \text{ m/s}^2) = 686 \text{ N}$$

Example 5.8 Apparent weight in an elevator (cont.)

This is an intermediate step in the calculation, so we are keeping an extra significant figure. Anjay's apparent weight, which is the upward force of the scale on him, is greater than his actual weight, so there is a net upward force on Anjay. His acceleration must be upward as well. This is exactly the situation of Figure 5.9, so we can use this figure as the free-body diagram for this problem. We can find the net force on Anjay, and then we can use this net force to determine his acceleration. Once we know the acceleration, we can use kinematics to determine the time it takes for the elevator to stop.

Example 5.8 Apparent weight in an elevator (cont.)

SOLVE We can read components of vectors from the figure. The vertical component of Newton's second law for Anjay's motion is

$$\Sigma F_y = n - w = ma_y$$

n is the normal force, which is the scale force on Anjay, 750 N. w is his weight, 686 N. We can thus solve for a_y :

$$a_y = \frac{n - w}{m} = \frac{750 \text{ N} - 686 \text{ N}}{70 \text{ kg}} = +0.91 \text{ m/s}^2$$

Example 5.8 Apparent weight in an elevator (cont.)

The acceleration is positive and so is directed upward, exactly as we assumed—a good check on our work. The elevator is slowing down, but the acceleration is directed upward. This means that the elevator was moving *downward*, with a negative velocity, before it stopped.

Example 5.8 Apparent weight in an elevator (cont.)

To find the stopping time, we can use the kinematic equation

$$(v_y)_f = (v_y)_i + a_y \Delta t$$

The elevator is initially moving downward, so $(v_y)_i = -5.0$ m/s, and it then comes to a halt, so $(v_y)_f = 0$. We know the acceleration, so the time interval is

$$\Delta t = \frac{(v_y)_f - (v_y)_i}{a_y} = \frac{0 - (-5.0 \text{ m/s})}{0.91 \text{ m/s}^2} = 5.5 \text{ s}$$

Example 5.8 Apparent weight in an elevator (cont.)

ASSESS Think back to your experiences riding elevators. If the elevator is moving downward and then comes to rest, you “feel heavy.” This gives us confidence that our analysis of the motion is correct. And 5.0 m/s is a pretty fast elevator: At this speed, the elevator will be passing more than one floor per second. If you’ve been in a fast elevator in a tall building, you know that 5.5 s is reasonable for the time it takes for the elevator to slow to a stop.

Weightlessness

- A person in free fall has zero apparent weight.
- “Weightless” does not mean “no weight.”
- An object that is **weightless** has no apparent weight.



QuickCheck 5.4

What are the components of \vec{w} in the coordinate system shown?

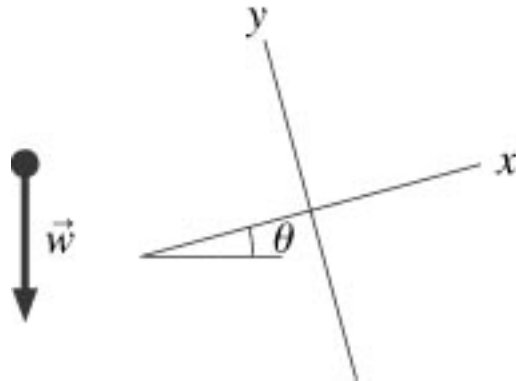

- A** $w_x = w \cos \theta$
 $w_y = w \sin \theta$
- B** $w_x = -w \cos \theta$
 $w_y = w \sin \theta$
- C** $w_x = w \cos \theta$
 $w_y = -w \sin \theta$
- D** $w_x = -w \sin \theta$
 $w_y = -w \cos \theta$
- E** $w_x = w \sin \theta$
 $w_y = -w \cos \theta$

QuickCheck 5.4

What are the components of \vec{w} in the coordinate system shown?

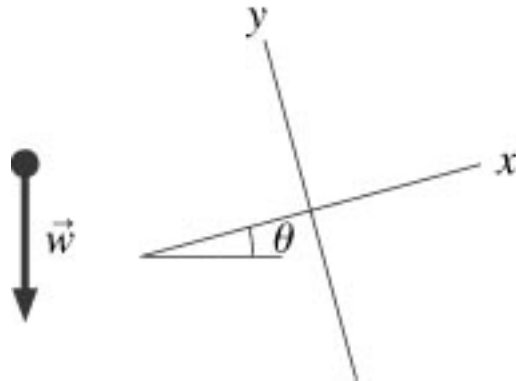

A $w_x = w \cos \theta$
 $w_y = w \sin \theta$

B $w_x = -w \cos \theta$
 $w_y = w \sin \theta$

C $w_x = w \cos \theta$
 $w_y = -w \sin \theta$

D $w_x = -w \sin \theta$
 $w_y = -w \cos \theta$ ✓

E $w_x = w \sin \theta$
 $w_y = -w \cos \theta$

QuickCheck 5.5

A 50-kg student ($mg = 490 \text{ N}$) gets in a 1000-kg elevator at rest and stands on a metric bathroom scale. As the elevator accelerates upward, the scale reads

- A. $> 490 \text{ N}$
- B. 490 N
- C. $< 490 \text{ N}$ but not 0 N
- D. 0 N

QuickCheck 5.5

A 50-kg student ($mg = 490 \text{ N}$) gets in a 1000-kg elevator at rest and stands on a metric bathroom scale. As the elevator accelerates upward, the scale reads

-  A. $> 490 \text{ N}$
- B. 490 N
- C. $< 490 \text{ N}$ but not 0 N
- D. 0 N

QuickCheck 5.6

A 50-kg student ($mg = 490 \text{ N}$) gets in a 1000-kg elevator at rest and stands on a metric bathroom scale. Sadly, the elevator cable breaks. What is the reading on the scale during the few seconds it takes the student to plunge to his doom?

- A. $> 490 \text{ N}$
- B. 490 N
- C. $< 490 \text{ N}$ but not 0 N
- D. 0 N

QuickCheck 5.6

A 50-kg student ($mg = 490 \text{ N}$) gets in a 1000-kg elevator at rest and stands on a metric bathroom scale. Sadly, the elevator cable breaks. What is the reading on the scale during the few seconds it takes the student to plunge to his doom?

A. $> 490 \text{ N}$

B. 490 N

C. $< 490 \text{ N}$ but not 0 N

 D. 0 N The bathroom scale would read 0 N .
Weight is reading of a scale on which the object is stationary *relative to the scale*.

Example Problem

A 50-kg student gets in a 1000-kg elevator at rest. As the elevator begins to move, she has an apparent weight of 600 N for the first 3 s. How far has the elevator moved, and in which direction, at the end of 3 s?

Section 5.4 Normal Forces

Normal Forces

- An object at rest on a table is subject to an upward force due to the table.
- This force is called the *normal force* because it is always directed normal, or perpendicular, to the surface of contact.
- The normal force adjusts itself so that the object stays on the surface without penetrating it.

Example 5.9 Normal force on a pressed book

A 1.2 kg book lies on a table. The book is pressed down from above with a force of 15 N. What is the normal force acting on the book from the table below?

PREPARE The book is not moving and is thus in static equilibrium. We need to identify the forces acting on the book and prepare a free-body diagram showing these forces. These steps are illustrated in FIGURE 5.10.

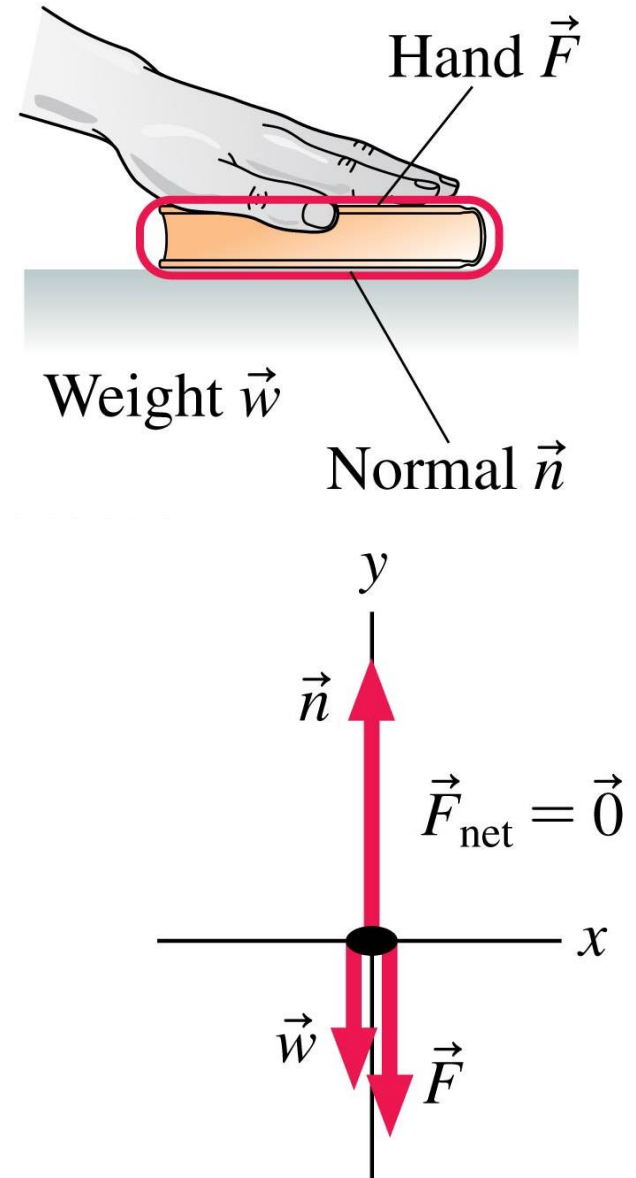

Example 5.9 Normal force on a pressed book (cont.)

SOLVE Because the book is in static equilibrium, the net force on it must be zero. The only forces acting are in the y -direction, so Newton's second law is

$$\Sigma F_y = n_y + w_y + F_y = n - w - F = ma_y = 0$$

We learned in the last section that the weight force is $w = mg$. The weight of the book is thus

$$w = mg = (1.2 \text{ kg})(9.8 \text{ m/s}^2) = 12 \text{ N}$$

With this information, we see that the normal force exerted by the table is

$$n = F + w = 15 \text{ N} + 12 \text{ N} = 27 \text{ N}$$

Example 5.9 Normal force on a pressed book (cont.)

ASSESS The magnitude of the normal force is *larger* than the weight of the book. From the table's perspective, the extra force from the hand pushes the book further into the atomic springs of the table. These springs then push back harder, giving a normal force that is greater than the weight of the book.

Normal Forces

(a) Analyzing forces on an incline

The normal force always points perpendicular to the surface.

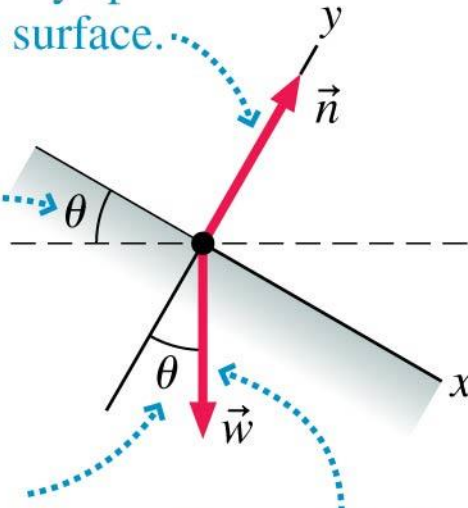

When we rotate the x -axis to match the surface, the angle between \vec{w} and the negative y -axis is the same as the angle θ of the slope.

The weight force always points straight down.

\vec{w} can be decomposed into x - and y -components.

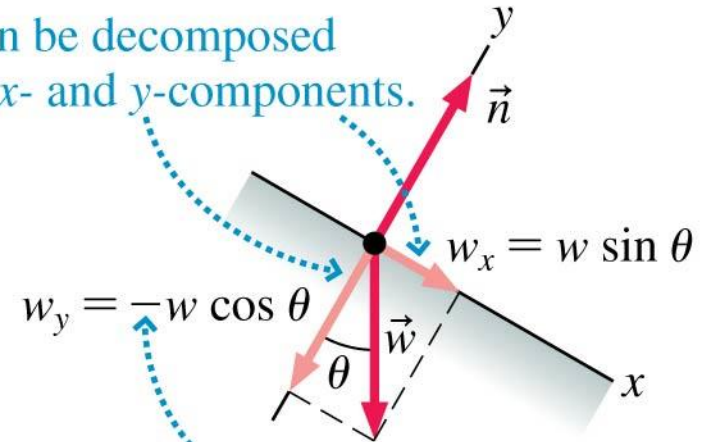

w_y is negative because \vec{w} points in the negative y -direction.

Normal Forces

(b) Two common mistakes to avoid

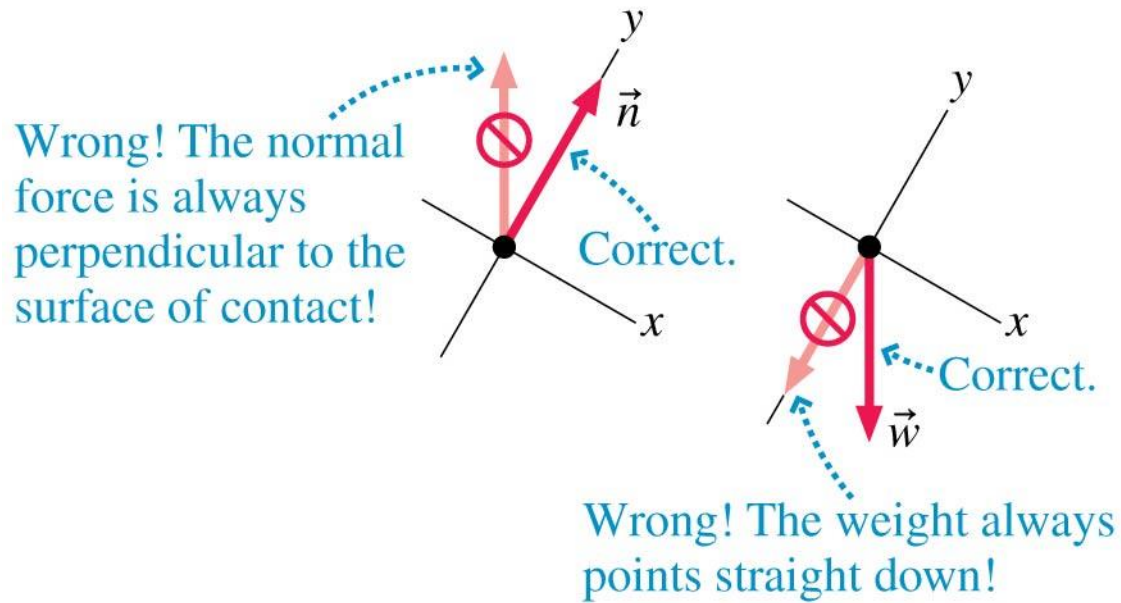

QuickCheck 5.2

The box is sitting on the floor of an elevator. The elevator is accelerating upward. The magnitude of the normal force on the box is

- A. $n > mg$
- B. $n = mg$
- C. $n < mg$
- D. $n = 0$
- E. Not enough information to tell

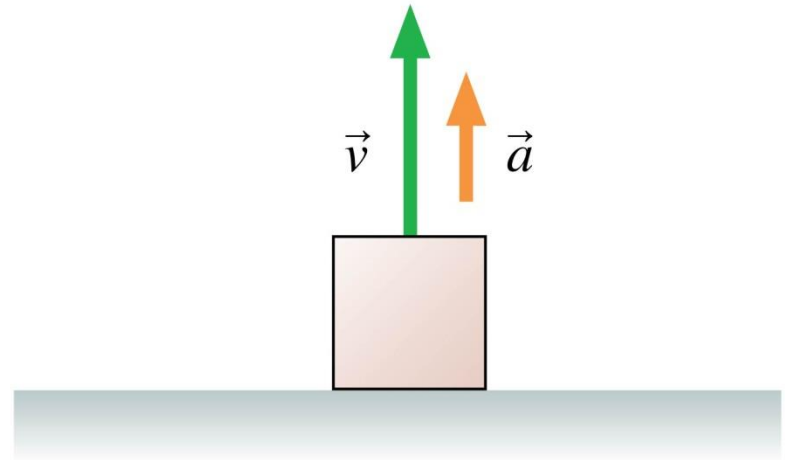

QuickCheck 5.2

The box is sitting on the floor of an elevator. The elevator is accelerating upward. The magnitude of the normal force on the box is

- ✓ A. $n > mg$
- B. $n = mg$
- C. $n < mg$
- D. $n = 0$
- E. Not enough information to tell

Upward acceleration requires a net upward force.

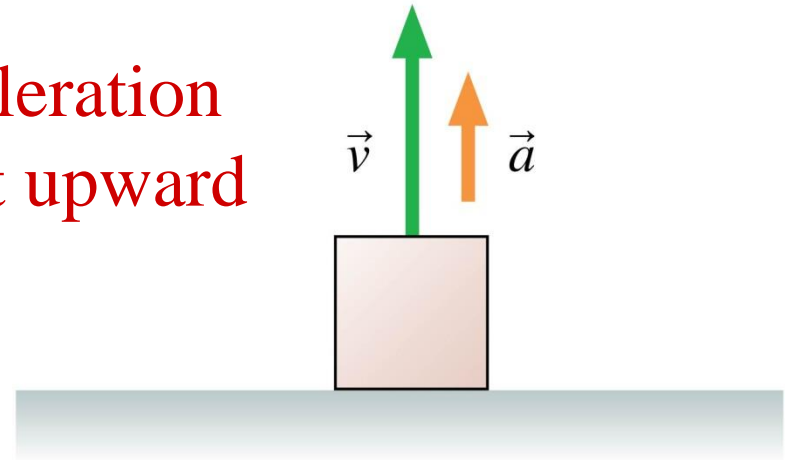

QuickCheck 5.3

A box is being pulled to the right at steady speed by a rope that angles upward. In this situation:

- A. $n > mg$
- B. $n = mg$
- C. $n < mg$
- D. $n = 0$
- E. Not enough information to judge the size of the normal force

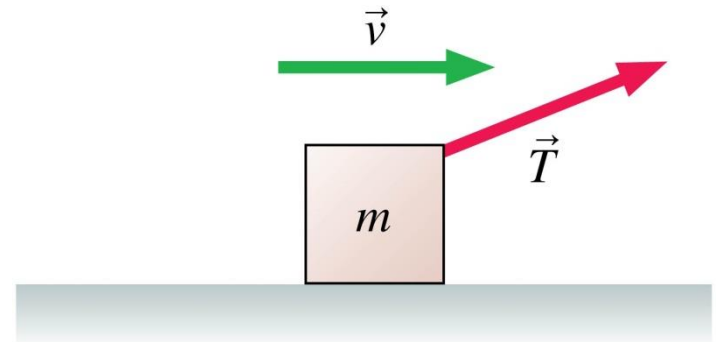

QuickCheck 5.3

A box is being pulled to the right at steady speed by a rope that angles upward. In this situation:

- A. $n > mg$
- B. $n = mg$
- ✓ C. $n < mg$
- D. $n = 0$
- E. Not enough information to judge the size of the normal force

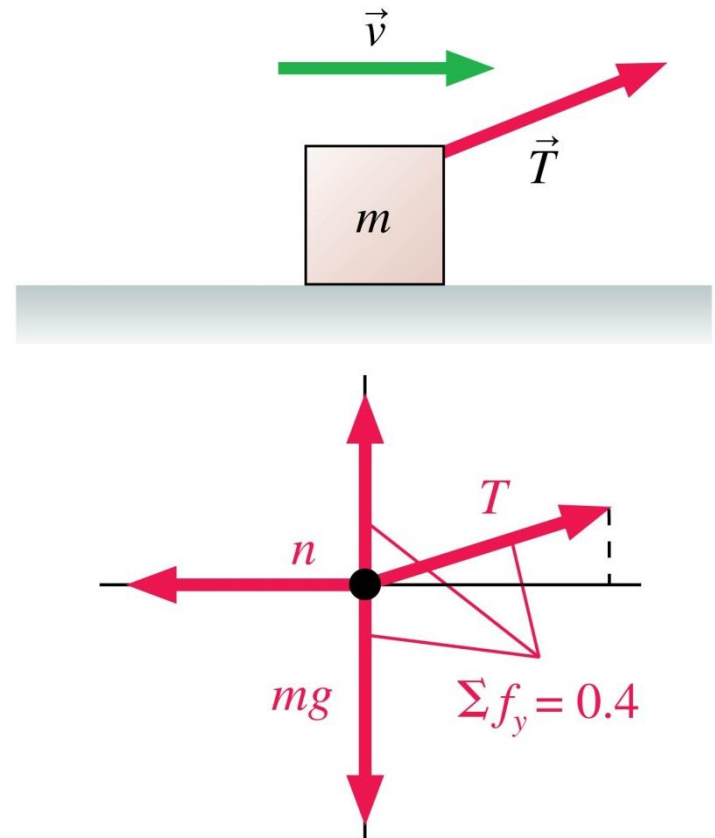

Example 5.10 Acceleration of a downhill skier

A skier slides down a steep 27° slope. On a slope this steep, friction is much smaller than the other forces at work and can be ignored. What is the skier's acceleration?

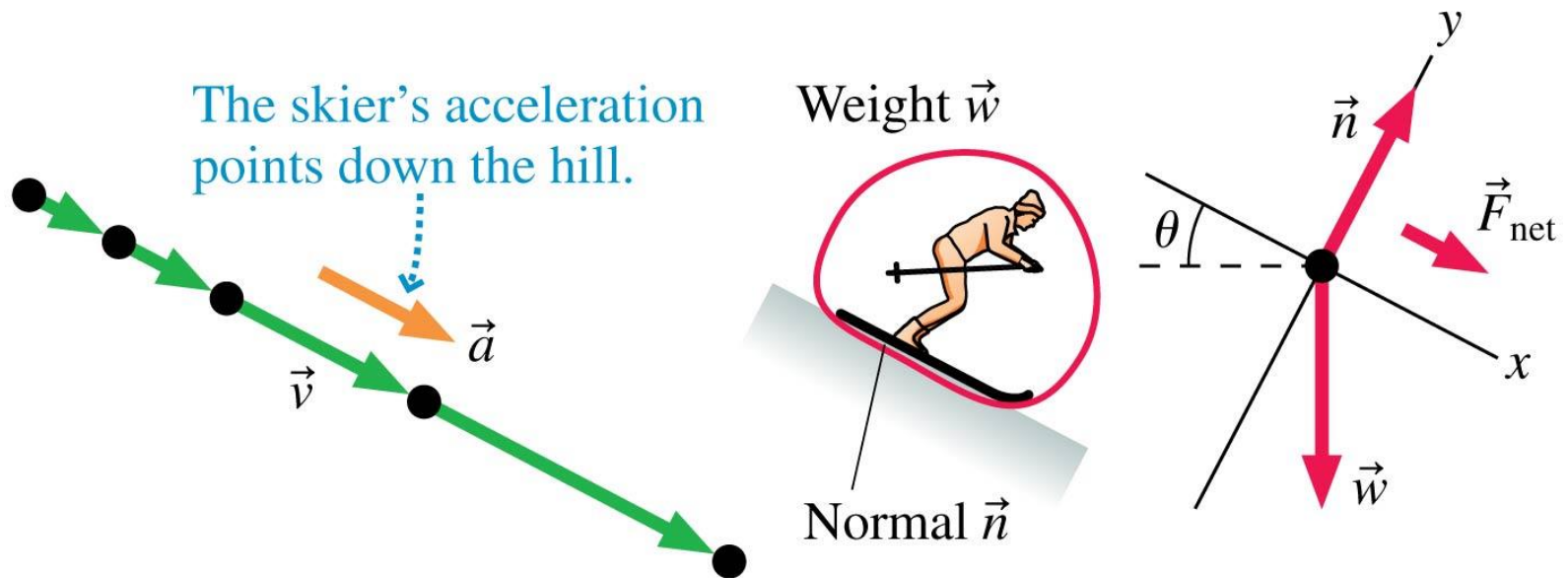

Example 5.10 Acceleration of a downhill skier (cont.)

PREPARE FIGURE 5.12 is a visual overview. We choose a coordinate system tilted so that the x -axis points down the slope. This greatly simplifies the analysis because with this choice $a_y = 0$ (the skier does not move in the y -direction at all). The free-body diagram is based on the information in Figure 5.11.

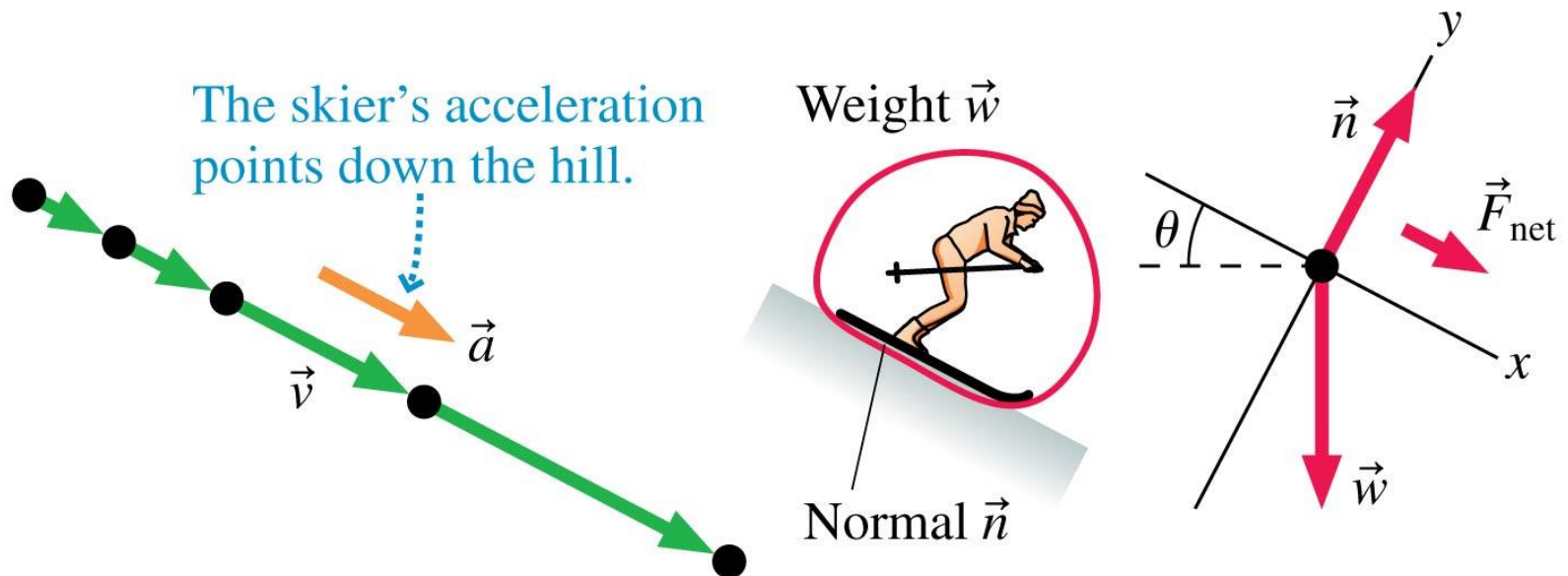

Example 5.10 Acceleration of a downhill skier (cont.)

SOLVE We can now use Newton's second law in component form to find the skier's acceleration:

$$\Sigma F_x = w_x + n_x = ma_x$$

$$\Sigma F_y = w_y + n_y = ma_y$$

Because \vec{n} points directly in the positive y -direction, $n_y = n$ and $n_x = 0$. Figure 5.11a showed the important fact that the angle between \vec{w} and the negative y -axis is the *same* as the slope angle θ . With this information, the components of \vec{w} are $w_x = w \sin \theta = mg \sin \theta$ and $w_y = -w \cos \theta = -mg \cos \theta$, where we used the fact that $w = mg$. With these components in hand, Newton's second law becomes

$$\Sigma F_x = w_x + n_x = m_x \sin \theta = ma_x$$

$$\Sigma F_y = w_y + n_y = -mg \cos \theta + n = ma_y = 0$$

Example 5.10 Acceleration of a downhill skier (cont.)

In the second equation we used the fact that $a_y = 0$. The m cancels in the first of these equations, leaving us with

$$a_x = g \sin \theta$$

This is the expression for acceleration on a frictionless surface that we presented, without proof, in Chapter 3. Now we've justified our earlier assertion. We can use this to calculate the skier's acceleration:

$$a_x = g \sin \theta = (9.8 \text{ m/s}^2) \sin 27^\circ = 4.4 \text{ m/s}^2$$

Example 5.10 Acceleration of a downhill skier (cont.)

ASSESS Our result shows that when $\theta = 0$, so that the slope is horizontal, the skier's acceleration is zero, as it should be. Further, when $\theta = 90^\circ$ (a vertical slope), his acceleration is g , which makes sense because he's in free fall when $\theta = 90^\circ$. Notice that the mass canceled out, so we didn't need to know the skier's mass. We first saw the formula for the acceleration in **Section 3.4**, but now we see the physical reasons behind it.

Section 5.5 Friction

Static Friction

- Static friction is the force that a surface exerts on an object to keep it from slipping across the surface.
- To find the direction of \vec{f}_s , decide which way the object would move if there were no friction. The static friction force then points in the opposite direction.

(a) Force identification

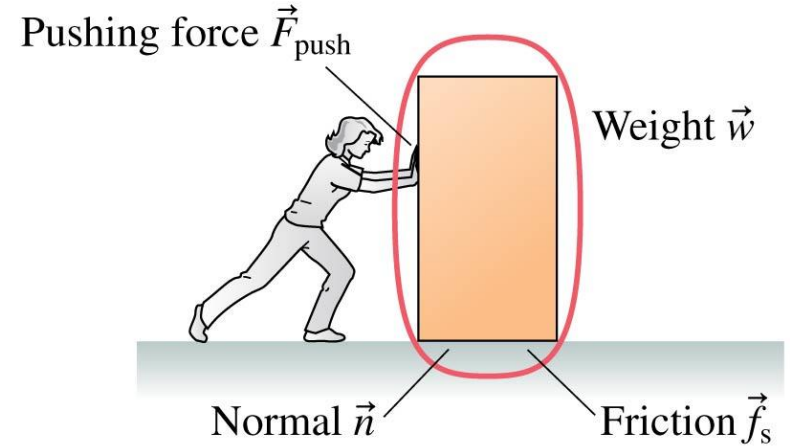

(b) Free-body diagram

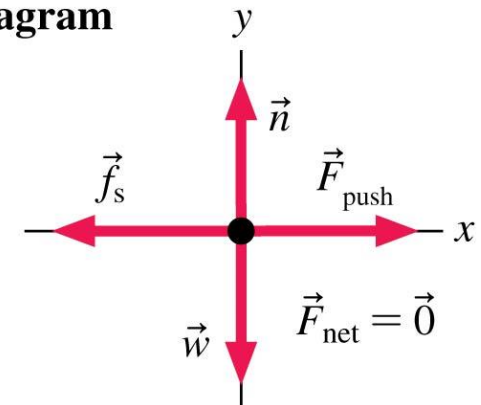

Static Friction

- The box is in static equilibrium.
- The static friction force must exactly balance the pushing force.

(a) Force identification

Pushing force \vec{F}_{push}

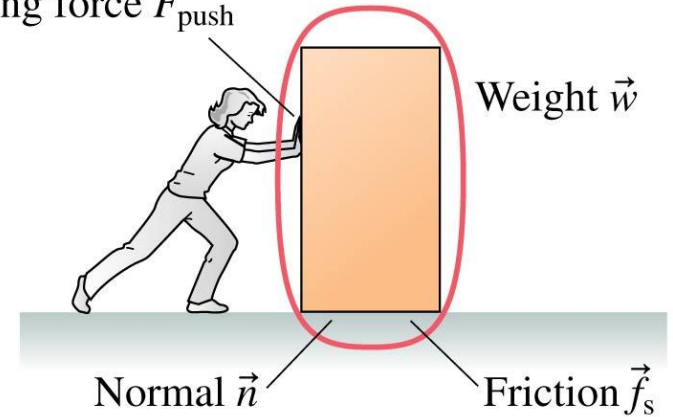

(b) Free-body diagram

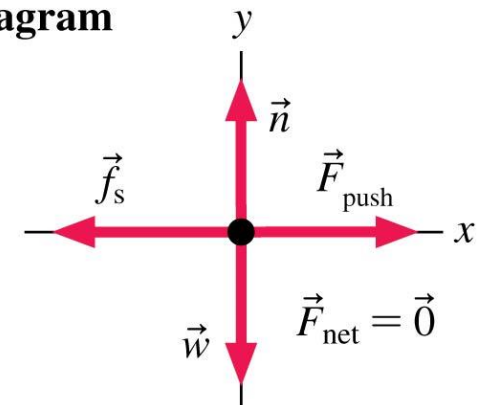

Static Friction

- The harder the woman pushes, the harder the friction force from the floor pushes back.
- If the woman pushes hard enough, the box will slip and start to move.
- The static friction force has a maximum possible magnitude:

$$f_{s \max} = \mu_s n$$

where μ_s is called the **coefficient of static friction**.

(a) Pushing gently: friction pushes back gently.

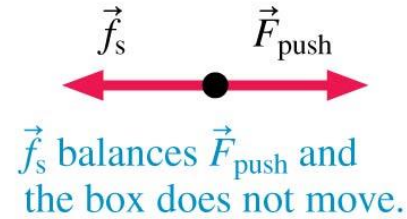

(b) Pushing harder: friction pushes back harder.

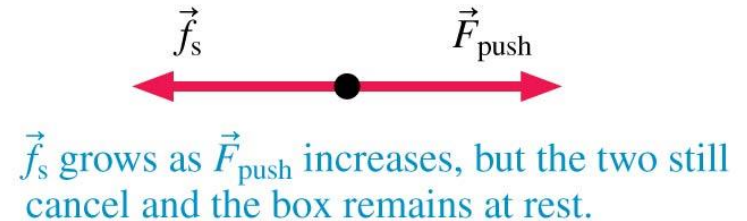

(c) Pushing harder still: \vec{f}_s is now pushing back as hard as it can.

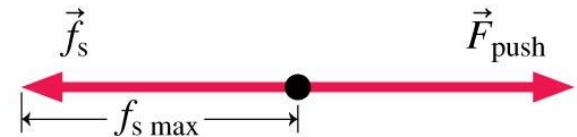

Static Friction

- The direction of static friction is such as to oppose motion.
- The magnitude f_s of static friction adjusts itself so that the net force is zero and the object doesn't move.
- The magnitude of static friction cannot exceed the maximum value $f_{s \text{ max}}$ given by Equation 5.7. If the friction force needed to keep the object stationary is greater than $f_{s \text{ max}}$, the object slips and starts to move.

QuickCheck 5.7

A box on a rough surface is pulled by a horizontal rope with tension T . The box is not moving. In this situation:

- A. $f_s > T$
- B. $f_s = T$
- C. $f_s < T$
- D. $f_s = \mu_s m g$
- E. $f_s = 0$

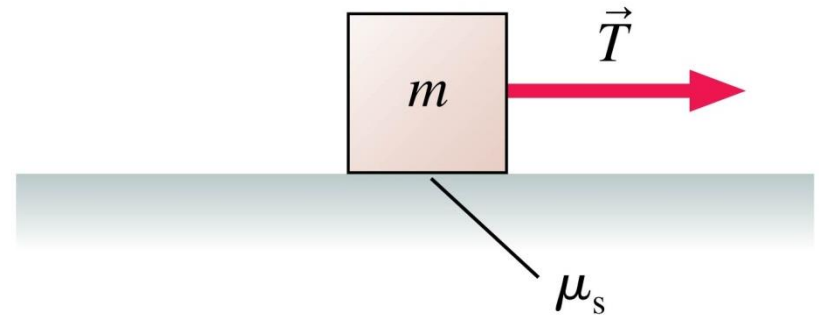

QuickCheck 5.7

A box on a rough surface is pulled by a horizontal rope with tension T . The box is not moving. In this situation:

A. $f_s > T$

✓ B. $f_s = T$ Newton's first law

C. $f_s < T$

D. $f_s = \mu_s mg$

E. $f_s = 0$

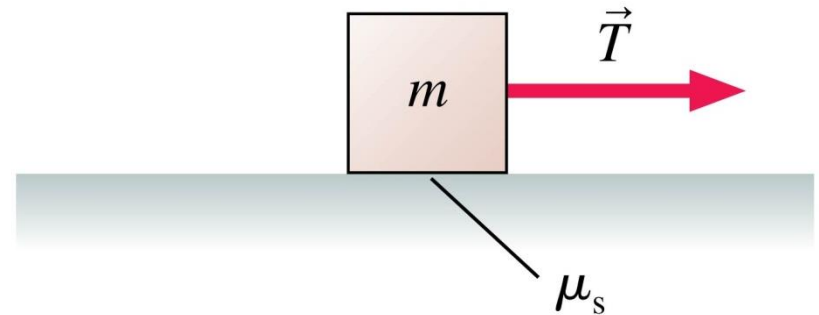

Kinetic Friction

- Kinetic friction, unlike static friction, has a nearly constant magnitude given by

$$f_k = \mu_k n$$

where μ_k is called the **coefficient of kinetic friction**.

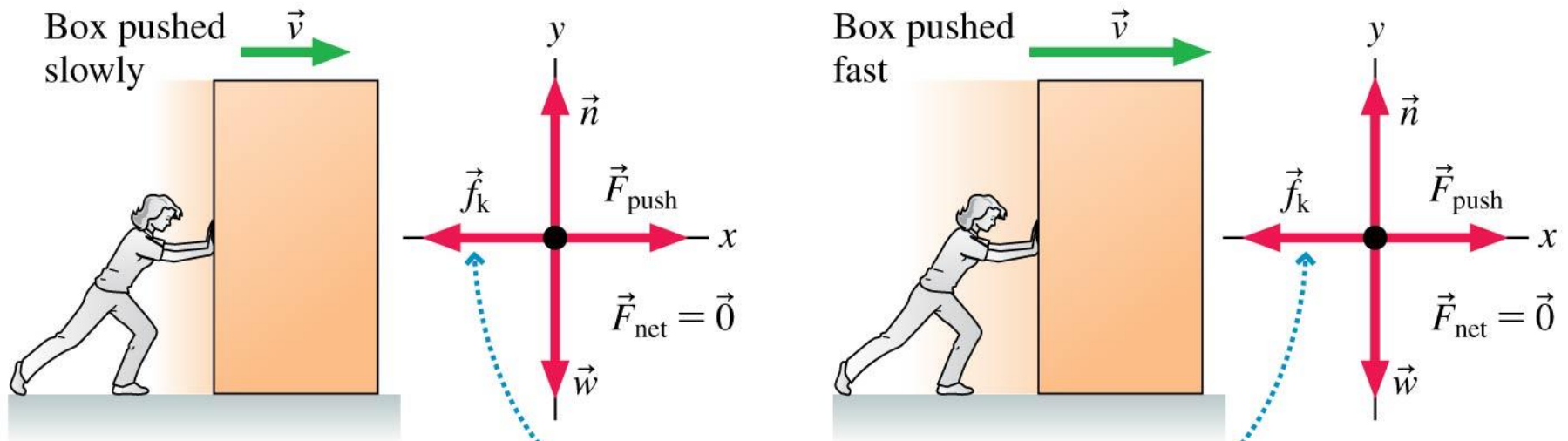

The kinetic friction force is the same no matter how fast the object slides.

Rolling Friction

- A wheel rolling on a surface experiences friction, but not kinetic friction: The portion of the wheel that contacts the surface is stationary with respect to the surface, not sliding.
- The interaction between a rolling wheel and the road can be quite complicated, but in many cases we can treat it like another type of friction force that opposes the motion, one defined by a coefficient of rolling friction μ_r :

$$f_r = \mu_r n$$

Friction Forces

TABLE 5.2 Coefficients of friction

Materials	Static μ_s	Kinetic μ_k	Rolling μ_r
Rubber on concrete	1.00	0.80	0.02
Steel on steel (dry)	0.80	0.60	0.002
Steel on steel (lubricated)	0.10	0.05	
Wood on wood	0.50	0.20	
Wood on snow	0.12	0.06	
Ice on ice	0.10	0.03	

Working with Friction Forces

Static: $\vec{f}_s = (\text{magnitude} \leq f_{s \max} = \mu_s n,$
direction as necessary to prevent motion)

Kinetic: $\vec{f}_k = (\mu_k n,$ direction opposite the motion)

Rolling: $\vec{f}_r = (\mu_r n,$ direction opposite the motion)

Working with Friction Forces

TACTICS BOX 5.1

Working with friction forces



- 1 If the object is *not moving* relative to the surface it's in contact with, then the friction force is **static friction**. Draw a free-body diagram of the object. The *direction* of the friction force is such as to oppose sliding of the object relative to the surface. Then use Problem-Solving Strategy 5.1 to solve for f_s . If f_s is greater than $f_{s\max} = \mu_s n$, then static friction cannot hold the object in place. The assumption that the object is at rest is not valid, and you need to redo the problem using kinetic friction.
- 2 If the object is *sliding* relative to the surface, then **kinetic friction** is acting. From Newton's second law, find the normal force n . Equation 5.10 then gives the magnitude and direction of the friction force.
- 3 If the object is *rolling* along the surface, then **rolling friction** is acting. From Newton's second law, find the normal force n . Equation 5.10 then gives the magnitude and direction of the friction force.

Exercises 20, 21 

Text: p. 140

QuickCheck 5.8

A box with a weight of 100 N is at rest. It is then pulled by a 30 N horizontal force.

Does the box move?

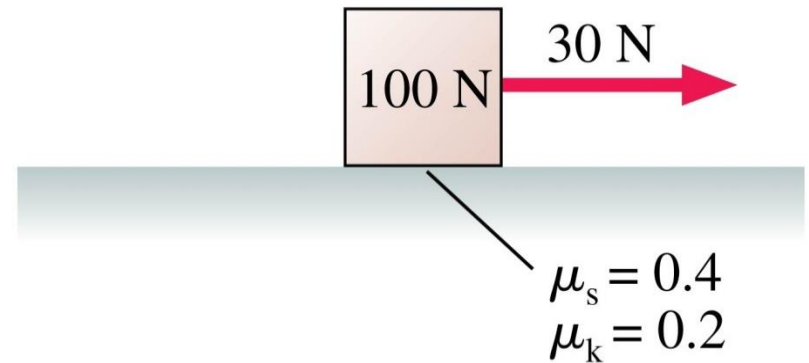

- A. Yes
- B. No
- C. Not enough information to say

QuickCheck 5.8

A box with a weight of 100 N is at rest. It is then pulled by a 30 N horizontal force.

Does the box move?

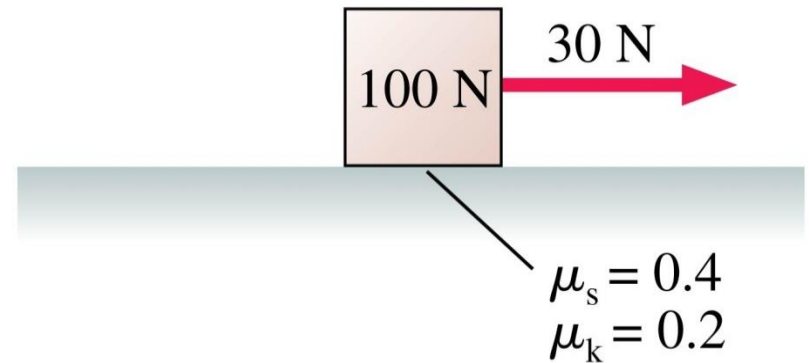

A. Yes

✓ B. No $30 \text{ N} < f_{s \text{ max}} = 40 \text{ N}$

C. Not enough information to say

Example 5.11 Finding the force to slide a sofa

Carol wants to move her 32 kg sofa to a different room in the house. She places “sofa sliders,” slippery disks with $\mu_k = 0.080$, on the carpet, under the feet of the sofa. She then pushes the sofa at a steady 0.40 m/s across the floor. How much force does she apply to the sofa?

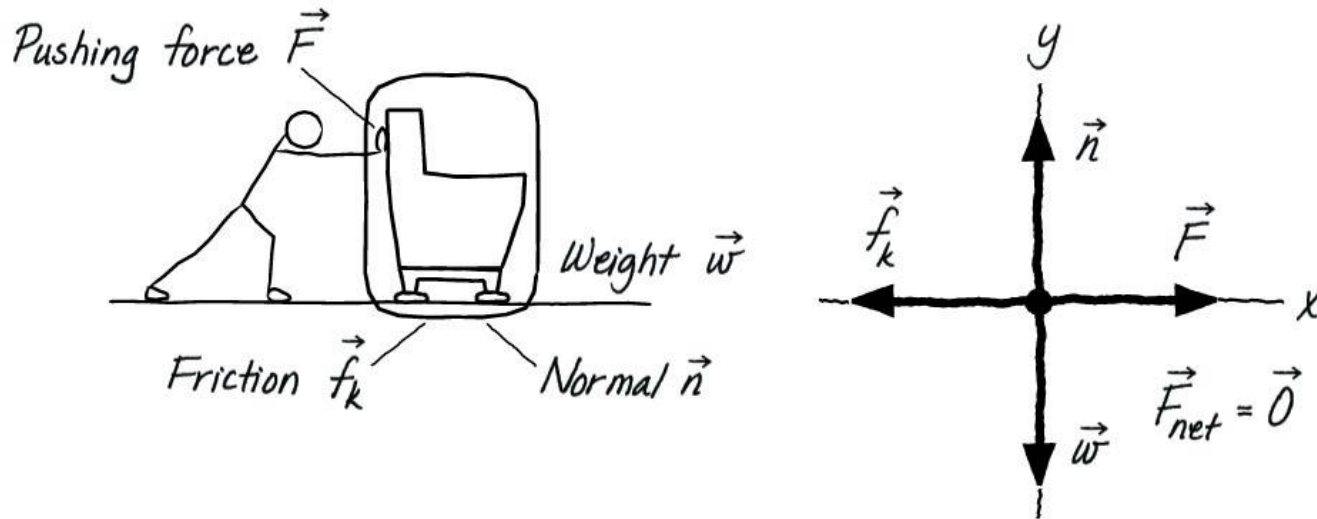

Example 5.11 Finding the force to slide a sofa (cont.)

PREPARE Let's assume the sofa slides to the right. In this case, a kinetic friction force \vec{f}_k , opposes the motion by pointing to the left. In FIGURE 5.17 we identify the forces acting on the sofa and construct a free-body diagram.

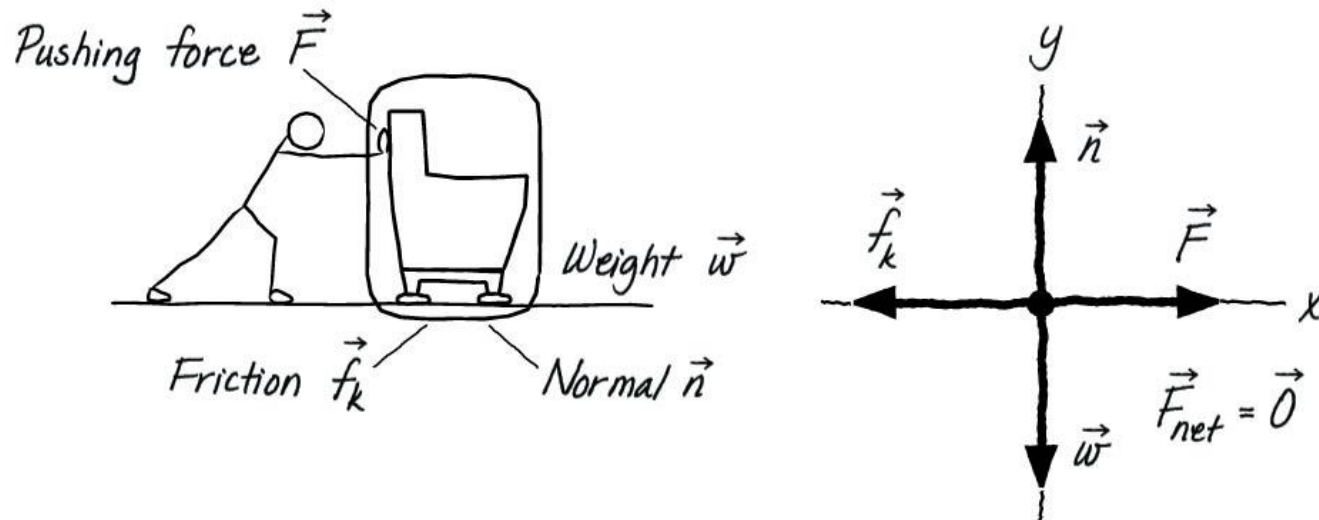

Example 5.11 Finding the force to slide a sofa (cont.)

SOLVE The sofa is moving at a constant speed, so it is in dynamic equilibrium with $\vec{F}_{\text{net}} = \vec{0}$. This means that the x - and y -components of the net force must be zero:

$$\Sigma F_x = n_x + w_x + F_x + (f_k)_x = 0 + 0 + F - f_k = 0$$

$$\Sigma F_y = n_y + w_y + F_y + (f_k)_y = n - w + 0 + 0 = 0$$

In the first equation, the x -component of \vec{f}_k is equal to $-f_k$ because \vec{f}_k is directed to the left. Similarly, $w_y = -w$ because the weight force points down.

From the first equation, we see that Carol's pushing force is $F = f_k$. To evaluate this, we need f_k . Here we can use our model for kinetic friction:

$$f_k = \mu_k n$$

Example 5.11 Finding the force to slide a sofa (cont.)

Let's look at the vertical motion first. The second equation ultimately reduces to

$$n - w = 0$$

The weight force $w = mg$, so we can write

$$n = mg$$

This is a common result we'll see again. The force that Carol pushes with is equal to the friction force, and this depends on the normal force and the coefficient of kinetic friction, $\mu_k = 0.080$:

$$\begin{aligned} F = f_k &= \mu_k n = \mu_k mg \\ &= (0.080)(32 \text{ kg})(9.80 \text{ m/s}^2) = 25 \text{ N} \end{aligned}$$

Example 5.11 Finding the force to slide a sofa (cont.)

ASSESS The speed with which Carol pushes the sofa does not enter into the answer. This makes sense because the kinetic friction force doesn't depend on speed. The final result of 25 N is a rather small force—only about 512 pounds—but we expect this because Carol has used slippery disks to move the sofa.

Causes of Friction

- All surfaces are very rough on a microscopic scale.
- When two objects are placed in contact, the high points on one surface become jammed against the high points on the other surface.
- The amount of contact depends on how hard the surfaces are pushed together.

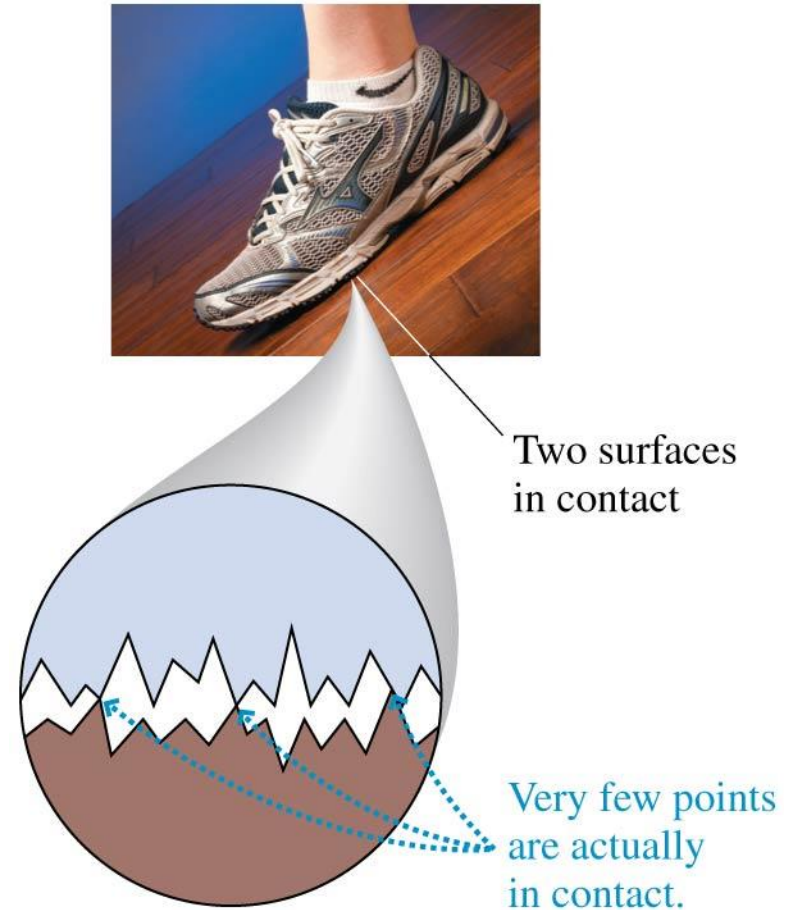

QuickCheck 5.9

A box is being pulled to the right over a rough surface. $T > f_k$, so the box is speeding up. Suddenly the rope breaks.

What happens? The box

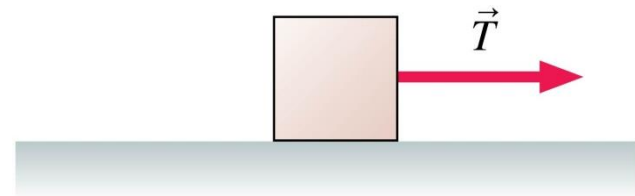

- A. Stops immediately.
- B. Continues with the speed it had when the rope broke.
- C. Continues speeding up for a short while, then slows and stops.
- D. Keeps its speed for a short while, then slows and stops.
- E. Slows steadily until it stops.

QuickCheck 5.9

A box is being pulled to the right over a rough surface.

$T > f_k$, so the box is speeding up. Suddenly the rope breaks.

What happens? The box

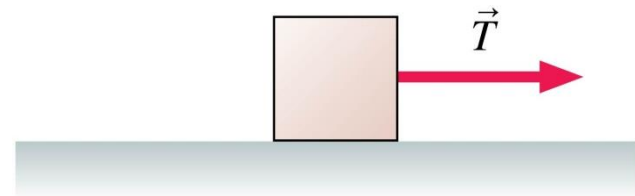

- A. Stops immediately.
- B. Continues with the speed it had when the rope broke.
- C. Continues speeding up for a short while, then slows and stops.
- D. Keeps its speed for a short while, then slows and stops.
- ✓ E. Slows steadily until it stops.

Example Problem

A car traveling at 20 m/s stops in a distance of 50 m.

Assume that the deceleration is constant. The coefficients of friction between a passenger and the seat are $\mu_s = 0.5$ and $\mu_k = 0.03$. Will a 70-kg passenger slide off the seat if not wearing a seat belt?

Section 5.6 Drag

Drag

- The drag force \vec{D} :
 - Is opposite in direction to the velocity \vec{v} .
 - Increases in magnitude as the object's speed increases.
- At relatively low speeds, the drag force in the air is small and can usually be ignored, but drag plays an important role as speeds increase. Fortunately, we can use a fairly simple *model* of drag if the following three conditions are met:
 - The object's size (diameter) is between a few millimeters and a few meters.
 - The object's speed is less than a few hundred meters per second.
 - The object is moving through the air near the earth's surface.

Drag

- In our everyday experience, the drag force can be written as

$$\vec{D} = \left(\frac{1}{2} C_D \rho A v^2, \text{ direction opposite the motion} \right)$$

- Here, ρ is the density of air ($\rho = 1.2 \text{ kg/m}^3$ at sea level), A is the cross-section area of the object (in m^2), and the **drag coefficient** C_D depends on the details of the object's shape. However, the value of C_D for everyday moving objects is roughly $1/2$, so a good approximation to the drag force is

$$D = \frac{1}{4} \rho A v^2$$

Drag force on an object of cross-section area A moving at speed v

Terminal Speed

- Just after an object is released from rest, its speed is low and the drag force is small.
- As it falls farther, its speed and hence the drag force increase.
- The speed at which the exact balance between the upward drag force and the downward weight force causes an object to fall without acceleration is called the **terminal speed**.

(a) At low speeds, D is small and the ball falls with $a \approx g$.

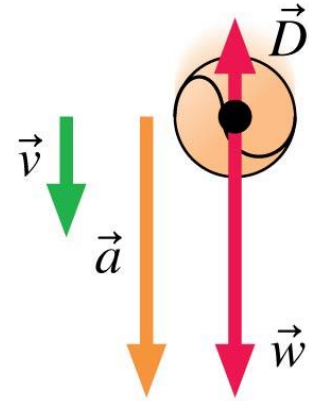

(b) Eventually, v reaches a value such that $D = w$. Then the net force is zero and the ball falls at a constant speed.

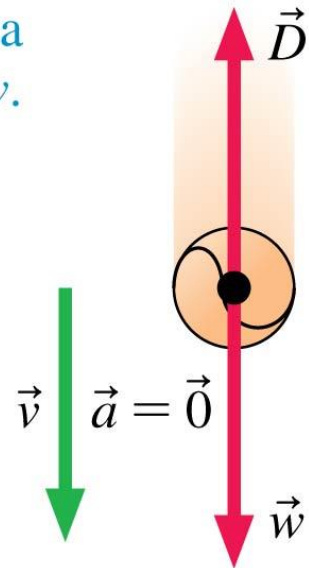

Example 5.14 Terminal speeds of a skydiver and a mouse

A skydiver and his pet mouse jump from a plane. Estimate their terminal speeds, assuming that they both fall in a prone position with limbs extended.

PREPARE There is no net force on a man or a mouse that has reached terminal speed. This is the situation shown in Figure 5.23b, where the drag force D and the weight w are equal in magnitude. Equating expressions for these two forces, we find that

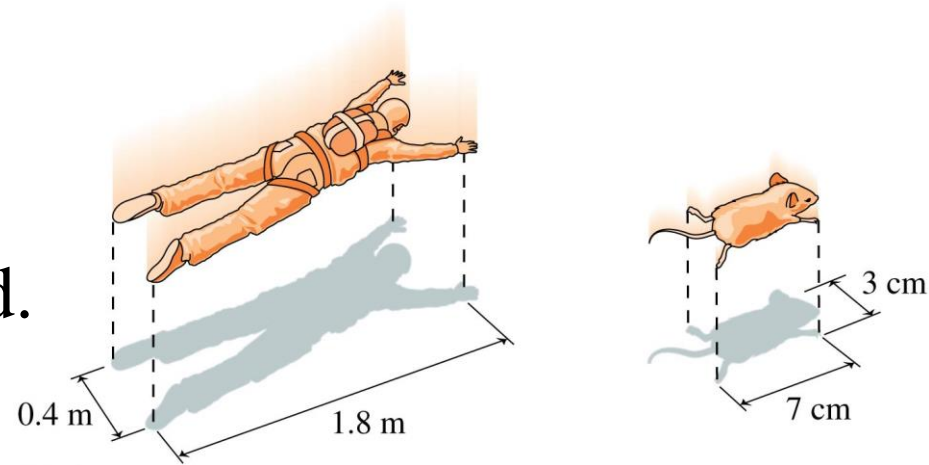

$$\frac{1}{4}\rho Av^2 = mg$$

Example 5.14 Terminal speeds of a skydiver and a mouse (cont.)

To solve this for the terminal speed v for both the man and the mouse, we need to estimate the mass m and cross-section area A of each. FIGURE 5.24 shows how.

A typical skydiver might be 1.8 m long and 0.4 m wide ($A = 0.72 \text{ m}^2$) with a mass of 75 kg, while a mouse has a mass of perhaps 20 g (0.020 kg) and is 7 cm long and 3 cm wide ($A = 0.07 \text{ m} \times 0.03 \text{ m} = 0.0021 \text{ m}^2$).

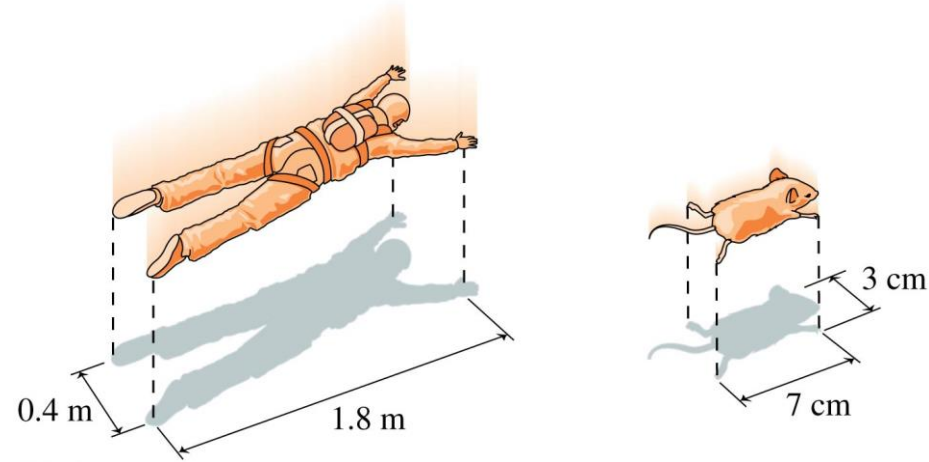

Example 5.14 Terminal speeds of a skydiver and a mouse (cont.)

SOLVE We can rearrange the equation to read

$$v = \sqrt{\frac{4mg}{\rho A}}$$

Using the numbers we estimated as well as the approximate density of air at sea level, we find the following values for the terminal speed:

$$v_{\text{man}} \approx \sqrt{\frac{4(75 \text{ kg})(9.80 \text{ m/s}^2)}{(1.2 \text{ kg/m}^3)(0.72 \text{ m}^2)}} = 60 \text{ m/s}$$

$$v_{\text{mouse}} \approx \sqrt{\frac{4(0.020 \text{ kg})(9.80 \text{ m/s}^2)}{(1.2 \text{ kg/m}^3)(0.0021 \text{ m}^2)}} = 20 \text{ m/s}$$

Example 5.14 Terminal speeds of a skydiver and a mouse (cont.)

ASSESS The terminal speed that we calculated for a skydiver is close to what you find if you look up expected speeds for this activity. But how about the mouse? The terminal speed depends on the ratio of the mass to the cross-section area, m/A . Smaller values of this ratio lead to slower terminal speeds. Small animals have smaller values of this ratio and really do experience lower terminal speeds. A mouse, with its very small value of m/A (and thus modest terminal speed), can typically survive a fall from *any* height with no ill effects! Small animals can reduce their terminal speed even further by increasing A . The frog in the photograph at the start of the chapter does this by stretching out its feet, and it experiences a gentle glide to the ground.

Catalog of Forces Revisited

Weight

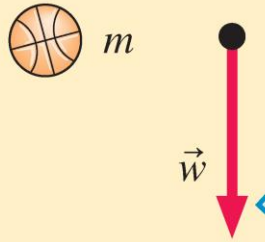

The weight force is always directed down.

Weight force (N) Mass (kg) Free-fall acceleration (9.80 m/s^2)

$$w = mg$$

The weight force is a long-range force. This formula applies near the earth's surface.

Text: p. 144

Catalog of Forces Revisited

Normal force

The normal force is always perpendicular to the surfaces that touch.

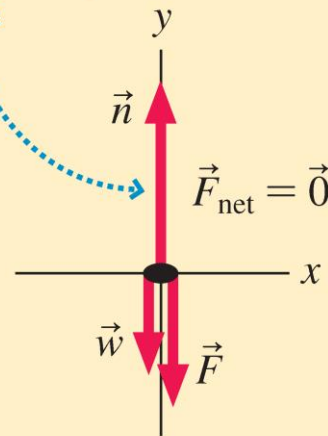
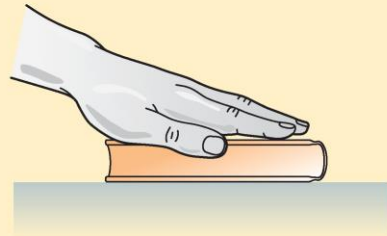

There is no formula for the normal force; we use Newton's laws as a guide to determine what the force must be.

Text: p. 144

Catalog of Forces Revisited

Spring and tension force

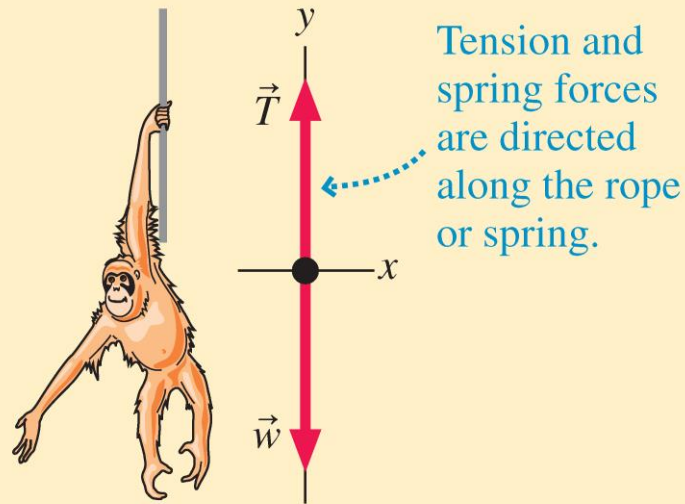

The spring force varies with the stretch of the spring, as we'll see later.

Text: p. 144

Catalog of Forces Revisited

Static friction

The static friction force opposes motion, up to a maximum value.

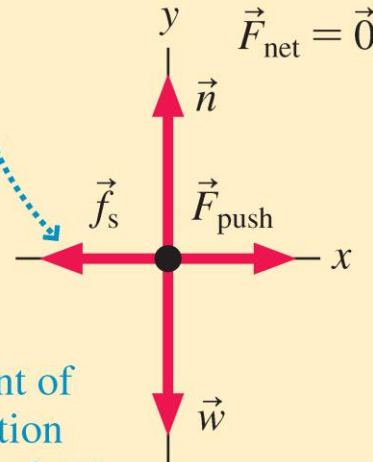
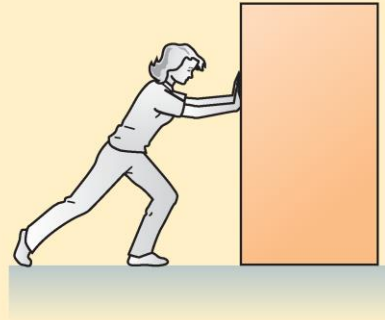

Maximum value of the static friction force (N)

Coefficient of static friction (dimensionless)

Normal force (N)

$$f_s \leq f_{s \max} = \mu_s n$$

Text: p. 144

Catalog of Forces Revisited

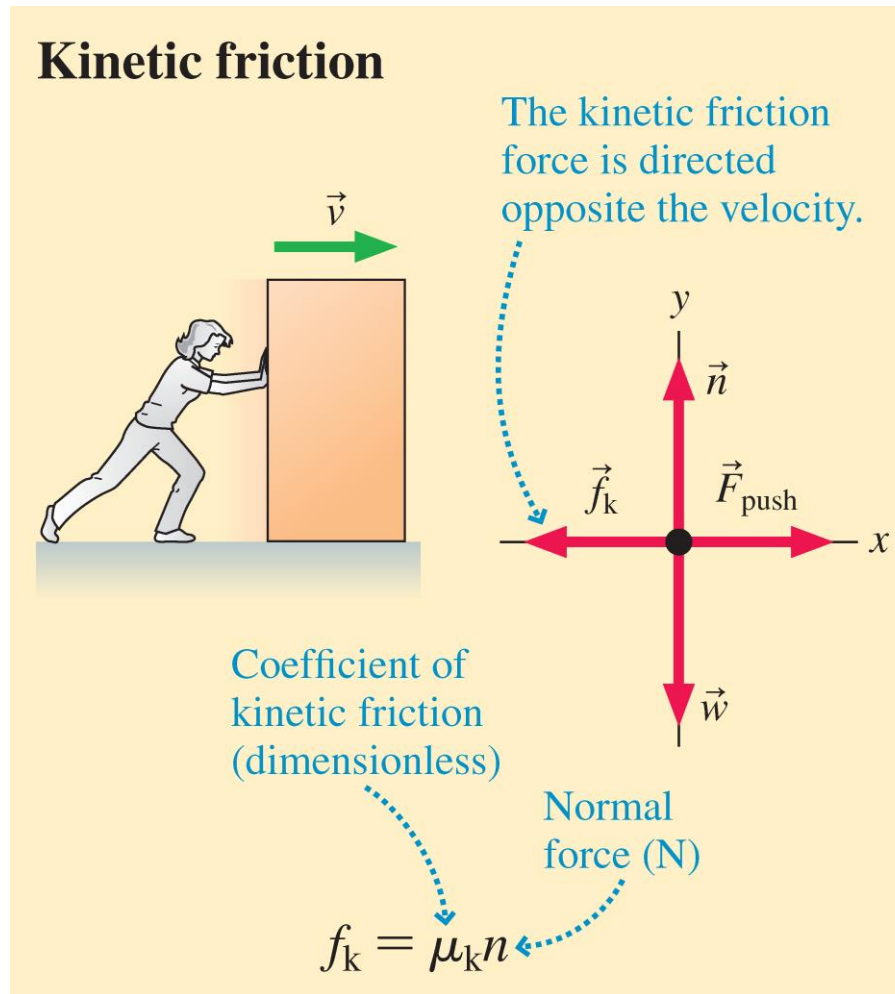

Text: p. 144

Catalog of Forces Revisited

Drag

The drag force is directed opposite the velocity.

Density of air (1.2 kg/m^3) Cross-section area (m^2) Speed (m/s)

$$D = \frac{1}{4} \rho A v^2$$

Text: p. 144

Catalog of Forces Revisited

SYNTHESIS 5.1 A catalog of forces

When solving mechanics problems, you'll often use the directions and details of the most common forces, outlined below.

Weight

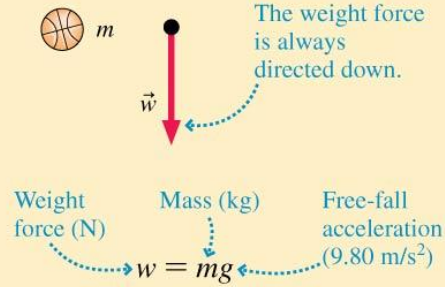

The weight force is a long-range force. This formula applies near the earth's surface.

Normal force

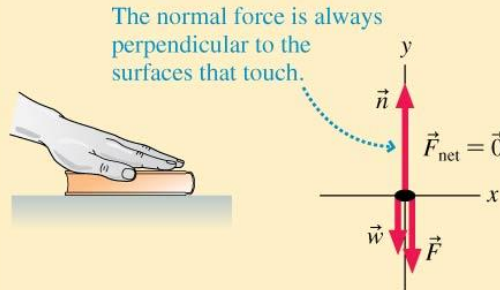

There is no formula for the normal force; we use Newton's laws as a guide to determine what the force must be.

Spring and tension force

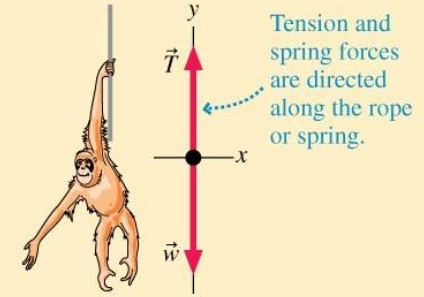

The spring force varies with the stretch of the spring, as we'll see later.

Static friction

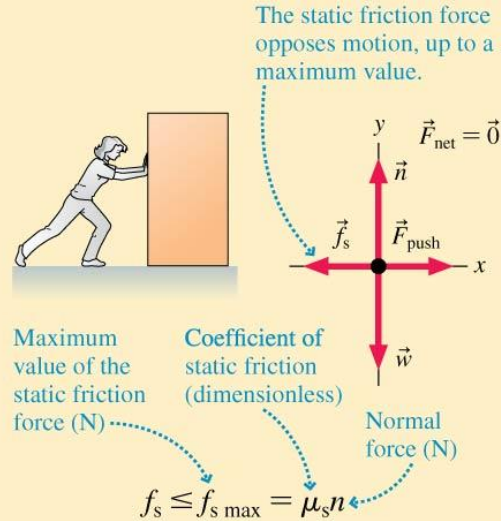

Kinetic friction

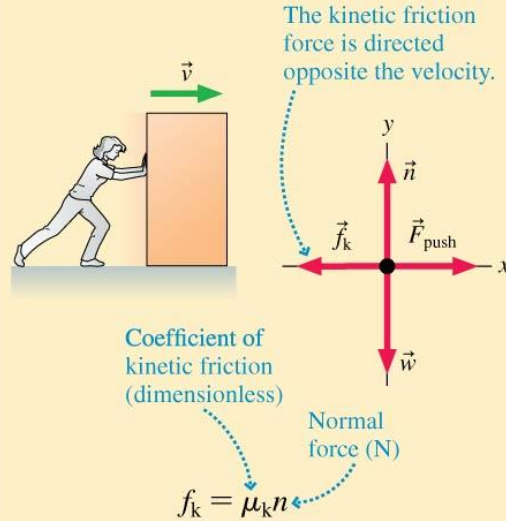

Drag

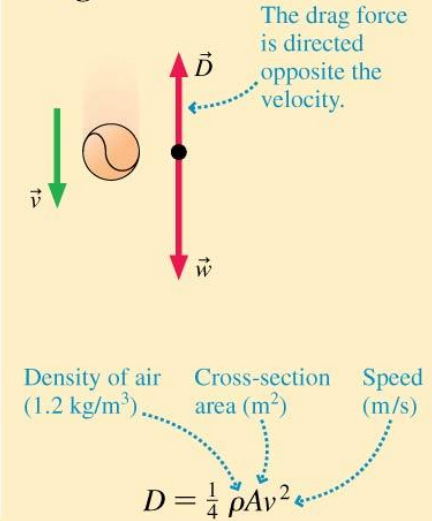

Section 5.7 Interacting Objects

Interacting Objects

- Newton's third law states:
 - Every force occurs as one member of an action/reaction pair of forces. The two members of the pair always act on *different* objects.
 - The two members of an action/reaction pair point in *opposite* directions and are equal in magnitude.

Objects in Contact

- To analyze block A's motion, we need to identify all the forces acting on it and then draw its free-body diagram.
- We repeat the same steps to analyze the motion of block B.
- However, the forces on A and B are *not* independent: Forces $\vec{F}_{B \text{ on } A}$ acting on block A and $\vec{F}_{A \text{ on } B}$ acting on block B are an action/reaction pair and thus have the same magnitude.
- Because the two blocks are in contact, their accelerations must be the same: $a_{Ax} = a_{Bx} = a_x$.
- We can't solve for the motion of one block without considering the motion of the other block.

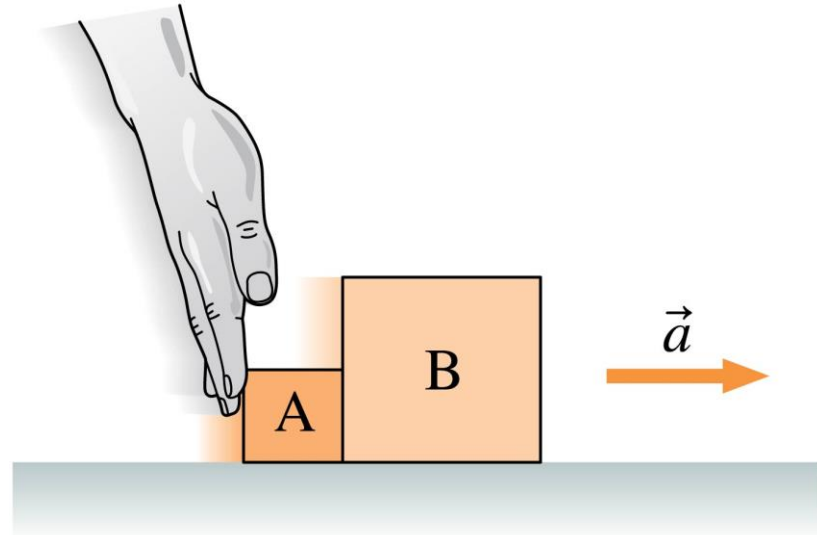

Objects in Contact

TACTICS BOX 5.2

Working with objects in contact



When two objects are in contact and their motion is linked, we need to duplicate certain steps in our analysis:

- 1 Draw each object separately and prepare a separate force identification diagram for *each* object.
- 2 Draw a separate free-body diagram for *each* object.
- 3 Write Newton's second law in component form for *each* object.

The two objects in contact exert forces on each other:

- 4 Identify the action/reaction pairs of forces. If object A acts on object B with force $\vec{F}_{A \text{ on } B}$, then identify the force $\vec{F}_{B \text{ on } A}$ that B exerts on A.
- 5 Newton's third law says that you can equate the magnitudes of the two forces in each action/reaction pair.

The fact that the objects are in contact simplifies the kinematics:

- 6 Objects in contact will have the same acceleration.

Exercises 25, 26, 27 

Text: p. 145

QuickCheck 5.11

Consider the situation in the figure. Which pair of forces is an action/reaction pair?

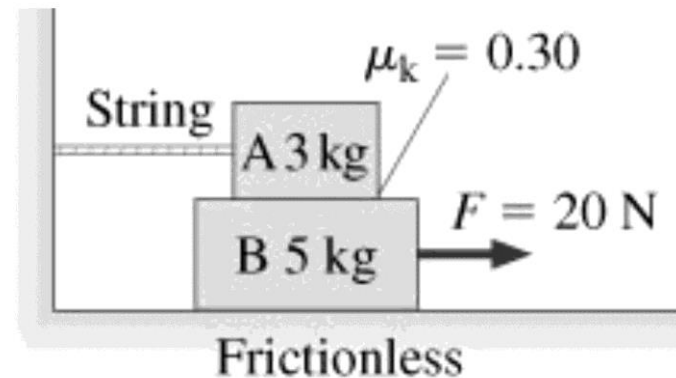

- A. The tension of the string and the friction force acting on A
- B. The normal force on A due to B and the weight of A
- C. The normal force on A due to B and the weight of B
- D. The friction force acting on A and the friction force acting on B

QuickCheck 5.11

Consider the situation in the figure. Which pair of forces is an action/reaction pair?

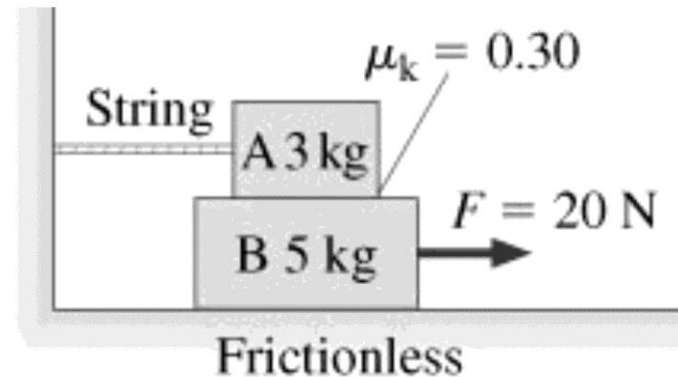

- A. The tension of the string and the friction force acting on A
- ✓ B. The normal force on A due to B and the weight of A
- C. The normal force on A due to B and the weight of B
- D. The friction force acting on A and the friction force acting on B

Example 5.15 Pushing two blocks

FIGURE 5.26 shows a 5.0 kg block A being pushed with a 3.0 N force. In front of this block is a 10 kg block B; the two blocks move together. What force does block A exert on block B?

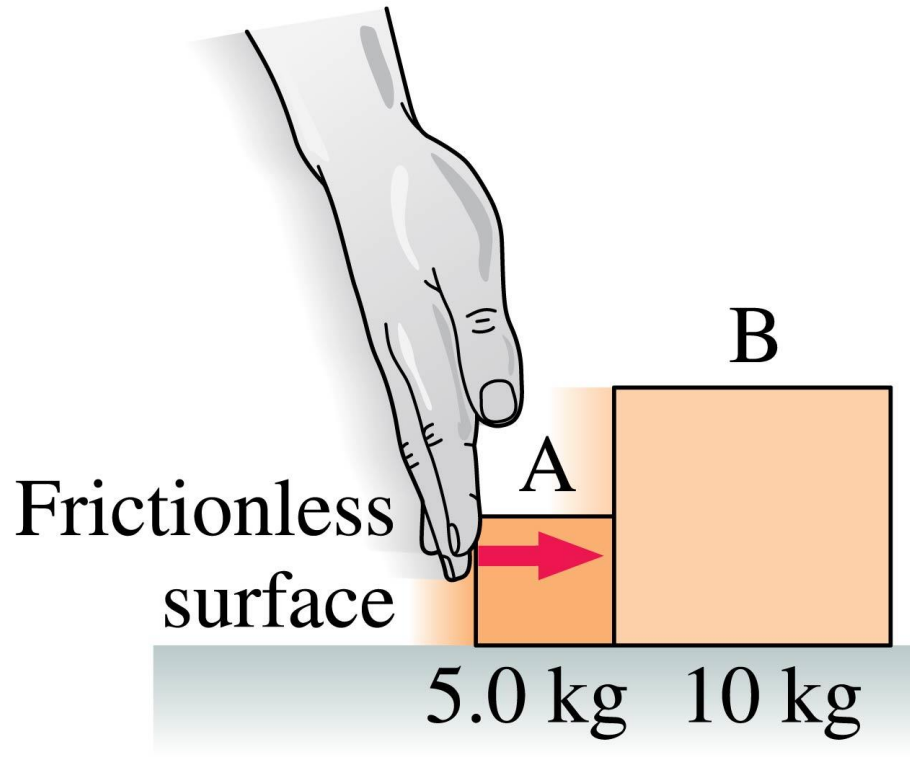

Example 5.15 Pushing two blocks (cont.)

PREPARE The visual overview of FIGURE 5.27 lists the known information and identifies $F_{A \text{ on } B}$ as what we're trying to find. Then, following the steps of Tactics Box 5.2, we've drawn *separate* force identification diagrams and *separate* free-body diagrams for the two blocks. Both blocks have a weight force and a normal force, so we've used subscripts A and B to distinguish between them.

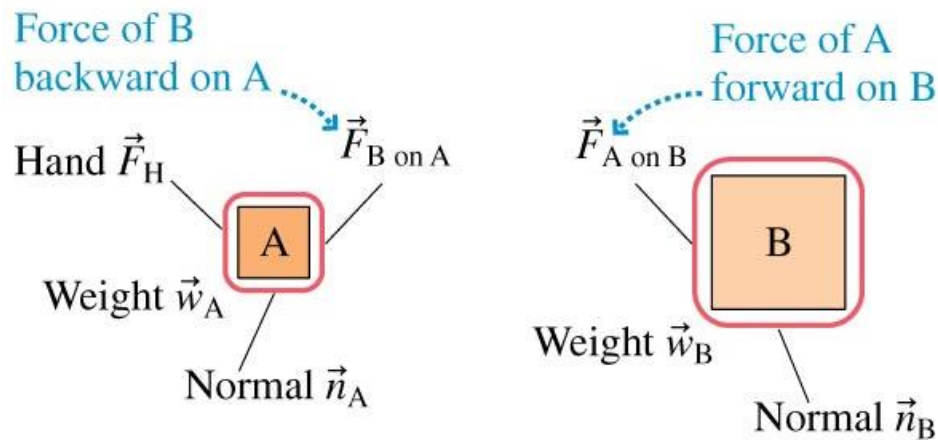

Example 5.15 Pushing two blocks (cont.)

The force $\vec{F}_{A \text{ on } B}$ is the contact force that block A exerts on B; it forms an action/reaction pair with the force $\vec{F}_{B \text{ on } A}$ that block B exerts on A. Notice that force $\vec{F}_{A \text{ on } B}$ is drawn acting on block B; it is the force *of* A

on B. **Force vectors are always drawn on the free-body diagram of the object that *experiences* the force, not the object exerting the force.** Because action/reaction pairs act in opposite directions, force $\vec{F}_{B \text{ on } A}$ pushes backward on block A and appears on A's free-body diagram.

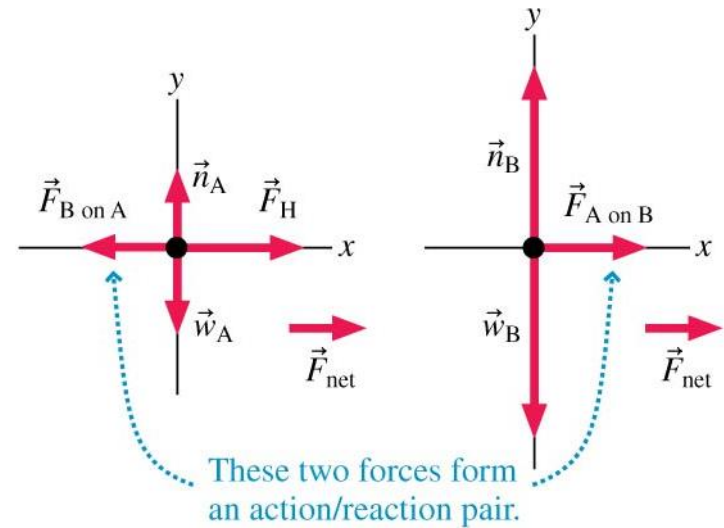

Example 5.15 Pushing two blocks (cont.)

SOLVE We begin by writing Newton's second law in component form for each block. Because the motion is only in the x -direction, we need only the x -component of the second law. For block A,

$$\Sigma F_x = (F_H)_x + (F_{B \text{ on } A})_x = m_A a_{Ax}$$

The force components can be “read” from the free-body diagram, where we see \vec{F} pointing to the right and $\vec{F}_{B \text{ on } A}$ pointing to the left. Thus

$$\Sigma F_H - F_{B \text{ on } A} = m_A a_{Ax}$$

<u>Known</u>
$m_A = 5.0 \text{ kg}$
$m_B = 10 \text{ kg}$
$F_H = 3.0 \text{ N}$
<u>Find</u>
$F_{A \text{ on } B}$

Example 5.15 Pushing two blocks (cont.)

For B, we have

$$\Sigma F_x = (F_{A \text{ on } B})_x = F_{A \text{ on } B} = m_B a_{Bx}$$

Known

$$m_A = 5.0 \text{ kg}$$

$$m_B = 10 \text{ kg}$$

$$F_H = 3.0 \text{ N}$$

Find

$$F_{A \text{ on } B}$$

We have two additional pieces of information:

First, Newton's third law tells us that $F_{B \text{ on } A} = F_{A \text{ on } B}$.

Second, the boxes are in contact and must have the same acceleration a_x ; that is, $a_{Ax} = a_{Bx} = a_x$. With this information, the two x -component equations become

$$F_H - F_{A \text{ on } B} = m_A a_x$$

$$F_{A \text{ on } B} = m_B a_x$$

Example 5.15 Pushing two blocks (cont.)

$$F_H - F_{A \text{ on } B} = m_A a_x$$

$$F_{A \text{ on } B} = m_B a_x$$

Our goal is to find $F_{A \text{ on } B}$, so we need to eliminate the unknown acceleration a_x . From the second equation, $a_x = F_{A \text{ on } B}/m_B$. Substituting this into the first equation gives

$$F_H - F_{A \text{ on } B} = \frac{m_A}{m_B} F_{A \text{ on } B}$$

This can be solved for the force of block A on block B, giving

$$F_{A \text{ on } B} = \frac{F_H}{1 + m_A/m_B} = \frac{3.0 \text{ N}}{1 + (5.0 \text{ kg})/(10 \text{ kg})} = \frac{3.0 \text{ N}}{1.5} = 2.0 \text{ N}$$

Example 5.15 Pushing two blocks (cont.)

ASSESS Force F_H accelerates both blocks, a total mass of 15 kg, but force $F_{A \text{ on } B}$ accelerates only block B, with a mass of 10 kg. Thus it makes sense that $F_{A \text{ on } B} < F_H$.

QuickCheck 5.12

Boxes A and B are being pulled to the right on a frictionless surface; the boxes are speeding up. Box A has a larger mass than Box B. How do the two tension forces compare?

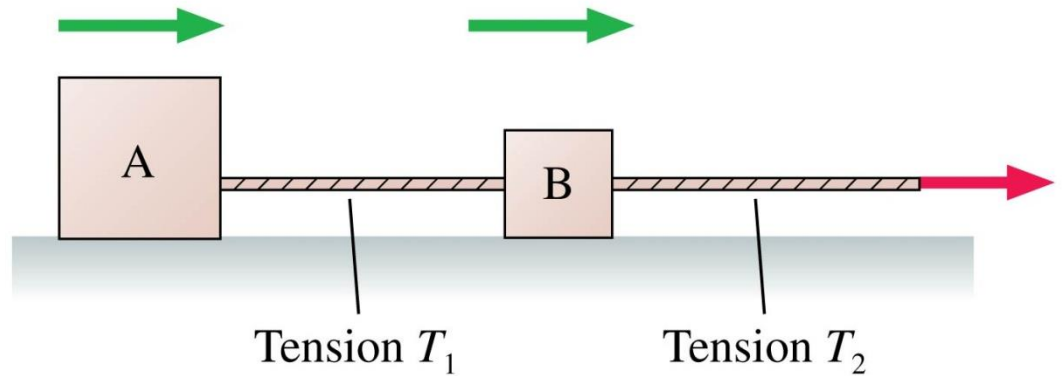

- A. $T_1 > T_2$
- B. $T_1 = T_2$
- C. $T_1 < T_2$
- D. Not enough information to tell

QuickCheck 5.12

Boxes A and B are being pulled to the right on a frictionless surface; the boxes are speeding up. Box A has a larger mass than Box B. How do the two tension forces compare?

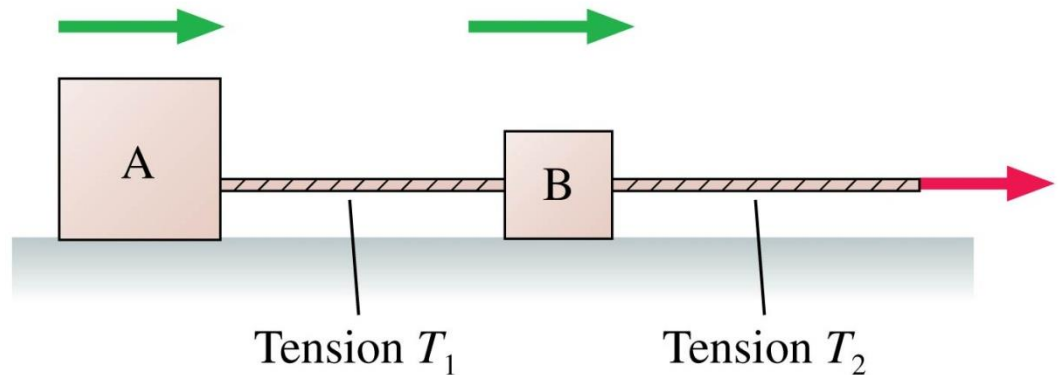

A. $T_1 > T_2$

B. $T_1 = T_2$

✓ C. $T_1 < T_2$

D. Not enough information to tell

QuickCheck 5.13

Boxes A and B are sliding to the right on a frictionless surface. Hand H is slowing them. Box A has a larger mass than Box B. Considering only the *horizontal* forces:

A. $F_{B \text{ on } H} = F_{H \text{ on } B} = F_{A \text{ on } B} = F_{B \text{ on } A}$

B. $F_{B \text{ on } H} = F_{H \text{ on } B} > F_{A \text{ on } B} = F_{B \text{ on } A}$

C. $F_{B \text{ on } H} = F_{H \text{ on } B} < F_{A \text{ on } B} = F_{B \text{ on } A}$

D. $F_{H \text{ on } B} = F_{H \text{ on } A} > F_{A \text{ on } B}$

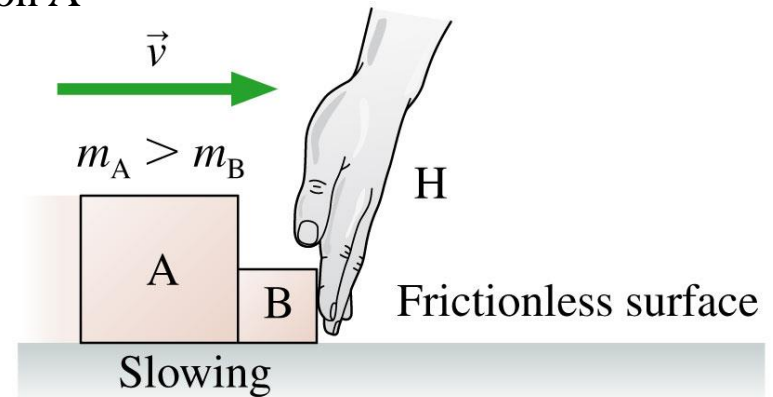

QuickCheck 5.13

Boxes A and B are sliding to the right on a frictionless surface. Hand H is slowing them. Box A has a larger mass than Box B. Considering only the *horizontal* forces:

A. $F_{B \text{ on } H} = F_{H \text{ on } B} = F_{A \text{ on } B} = F_{B \text{ on } A}$

 B. $F_{B \text{ on } H} = F_{H \text{ on } B} > F_{A \text{ on } B} = F_{B \text{ on } A}$

C. $F_{B \text{ on } H} = F_{H \text{ on } B} < F_{A \text{ on } B} = F_{B \text{ on } A}$

D. $F_{H \text{ on } B} = F_{H \text{ on } A} > F_{A \text{ on } B}$

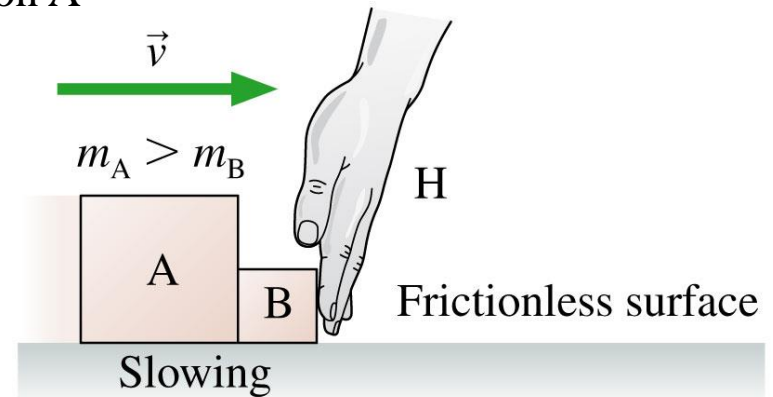

QuickCheck 5.14

The two masses are at rest. The pulleys are frictionless. The scale is in kg. The scale reads

- A. 0 kg
- B. 5 kg
- C. 10 kg

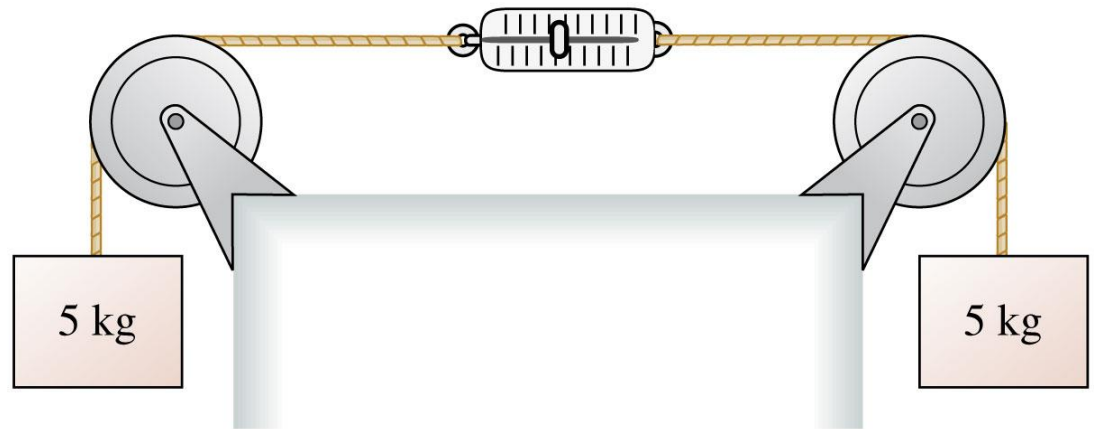

QuickCheck 5.14

The two masses are at rest. The pulleys are frictionless. The scale is in kg. The scale reads

- A. 0 kg
- ✓ B. 5 kg
- C. 10 kg

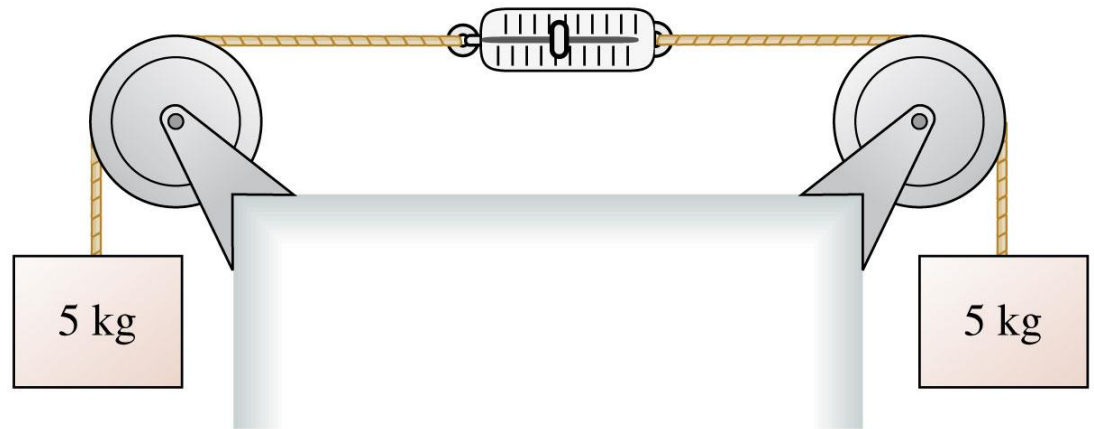

Section 5.8 Ropes and Pulleys

Ropes

- The box is pulled by the rope, so the box's free-body diagram shows a tension force \vec{T} .
- We make the massless string approximation that $m_{\text{rope}} = 0$.
- Newton's second law *for the rope* is thus

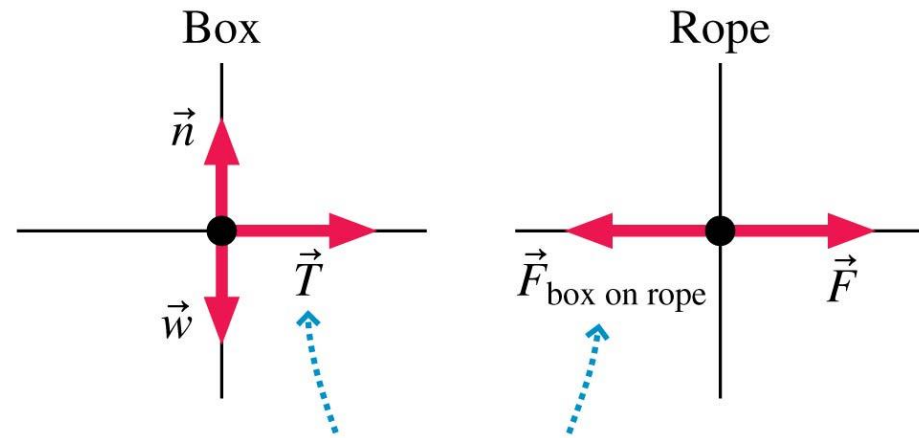
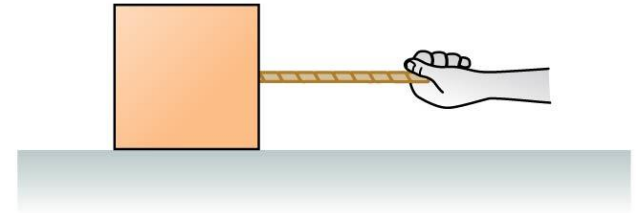

The tension \vec{T} is the force that the rope exerts on the box. Thus \vec{T} and $\vec{F}_{\text{box on rope}}$ are an action/reaction pair and have the same magnitude.

$$\Sigma F_x = F_{\text{box on rope}} = F - T = m_{\text{rope}} a_x = 0$$

Ropes

- **Generally, the tension in a massless string or rope equals the magnitude of the force pulling on the end of the string or rope. As a result:**
 - A massless string or rope “transmits” a force undiminished from one end to the other: If you pull on one end of a rope with force F , the other end of the rope pulls on what it’s attached to with a force of the same magnitude F .
 - The tension in a massless string or rope is the same from one end to the other.

QuickCheck 5.10

All three 50-kg blocks are at rest. The tension in rope 2 is

- A. Greater than the tension in rope 1.
- B. Equal to the tension in rope 1.
- C. Less than the tension in rope 1.

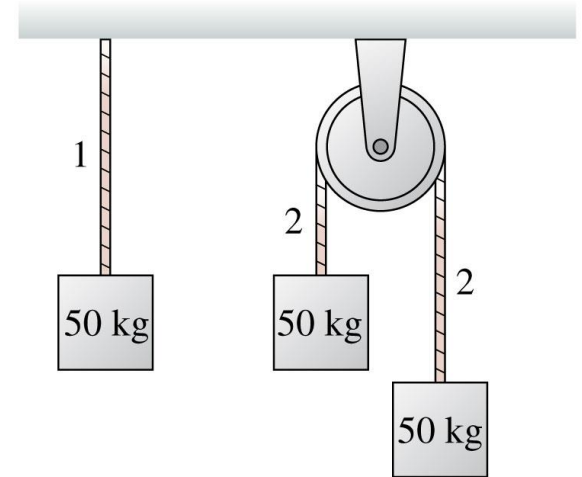

QuickCheck 5.10

All three 50-kg blocks are at rest. The tension in rope 2 is

A. Greater than the tension in rope 1.

✓ B. Equal to the tension in rope 1.

C. Less than the tension in rope 1.

Each block is in static equilibrium, with $\vec{F}_{\text{net}} = 0$.

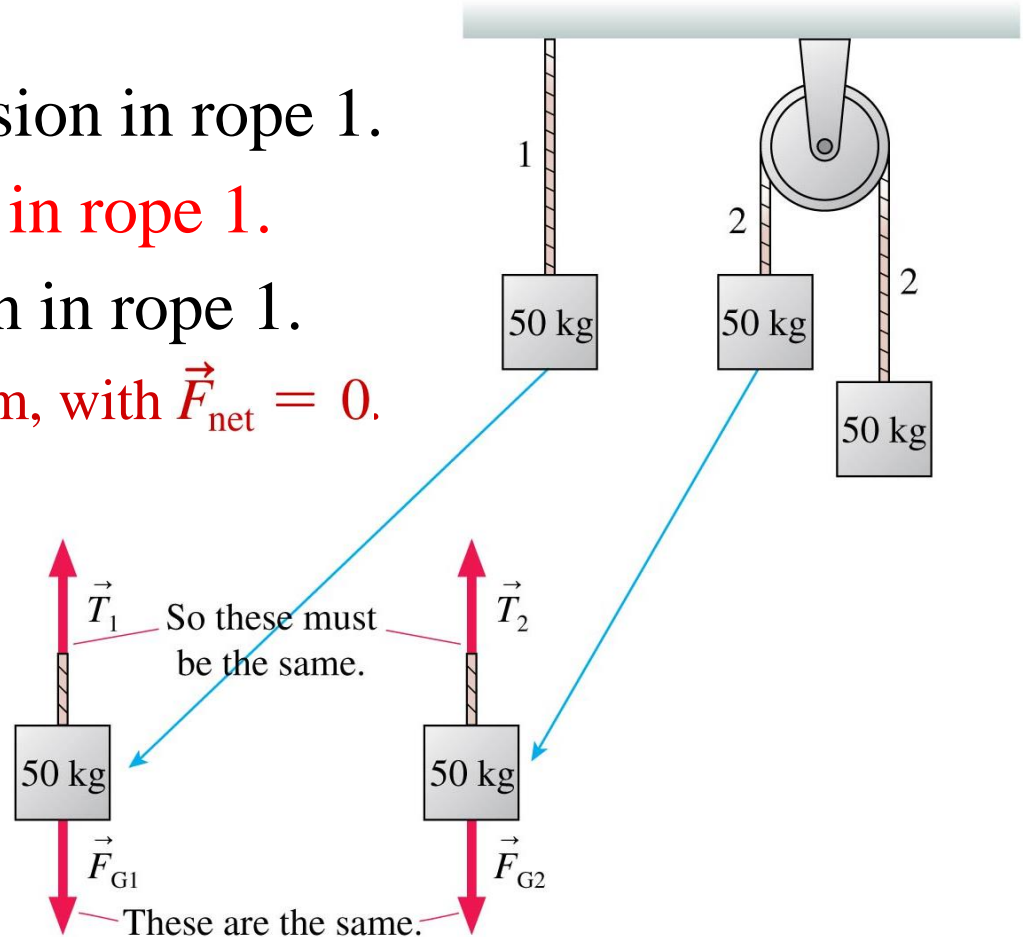

Example Problem

A wooden box, with a mass of 22 kg, is pulled at a constant speed with a rope that makes an angle of 25° with the wooden floor. What is the tension in the rope?

Pulleys

- The tension in a massless string is unchanged by passing over a massless, frictionless pulley.
- We'll assume such an ideal pulley for problems in this chapter.

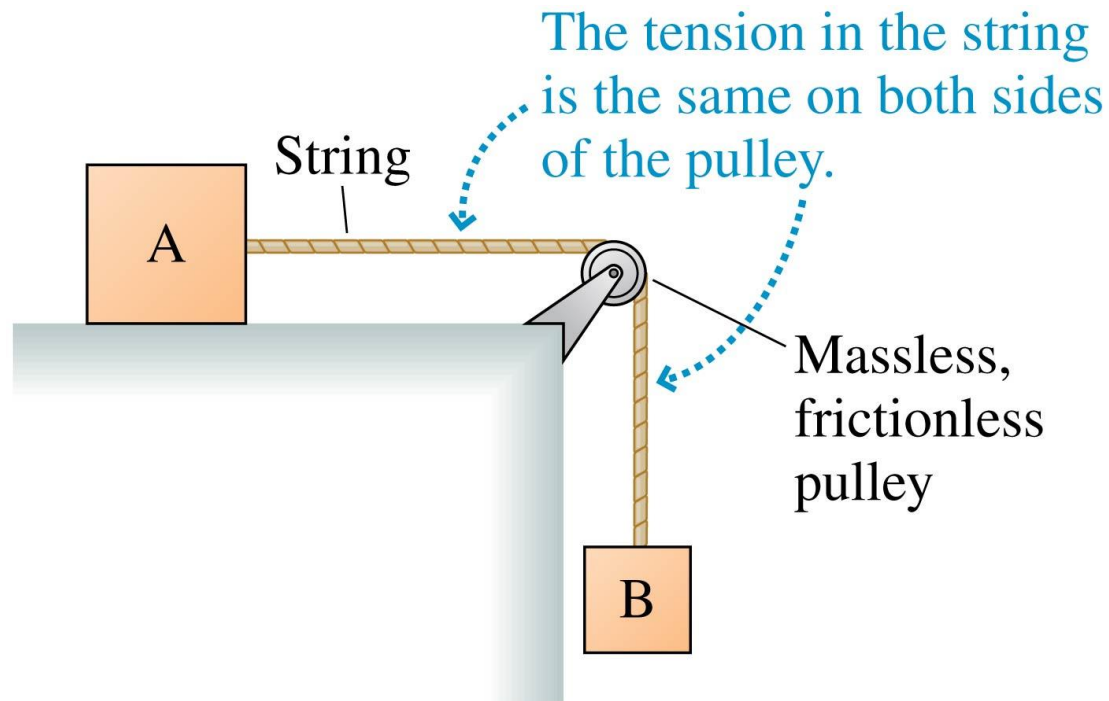

Ropes and Pulleys

TACTICS BOX 5.3

Working with ropes and pulleys



For massless ropes or strings and massless, frictionless pulleys:

- If a force pulls on one end of a rope, the tension in the rope equals the magnitude of the pulling force.
- If two objects are connected by a rope, the tension is the same at both ends.
- If the rope passes over a pulley, the tension in the rope is unaffected.

Exercises 29–32 

Text: p. 148

QuickCheck 5.15

The top block is accelerated across a frictionless table by the falling mass m . The string is massless, and the pulley is both massless and frictionless. The tension in the string is

- A. $T < mg$
- B. $T = mg$
- C. $T > mg$

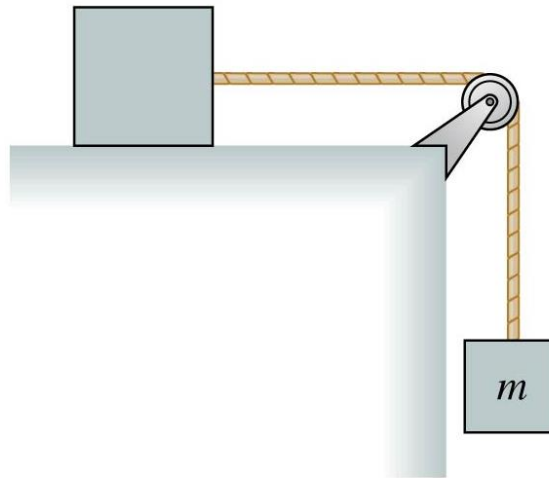

QuickCheck 5.15

The top block is accelerated across a frictionless table by the falling mass m . The string is massless, and the pulley is both massless and frictionless. The tension in the string is

- ✓ A. $T < mg$
B. $T = mg$
C. $T > mg$

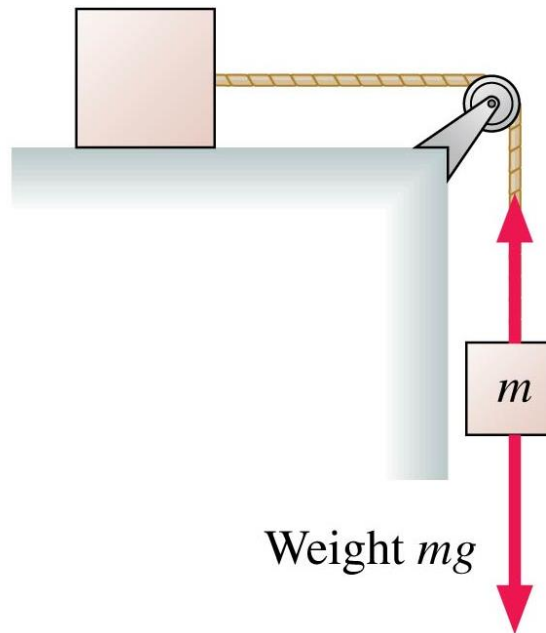

Tension has to be less than mg for the block to have a downward acceleration.

Example 5.18 Lifting a stage set

A 200 kg set used in a play is stored in the loft above the stage. The rope holding the set passes up and over a pulley, then is tied backstage. The rope holding the set passes up and over a pulley, then is tied backstage. The director tells a 100 kg stagehand to lower the set. When he unties the rope, the set falls and the unfortunate man is hoisted into the loft. What is the stagehand's acceleration?

Known
$m_M = 100 \text{ kg}$
$m_S = 200 \text{ kg}$
Find
a_{My}

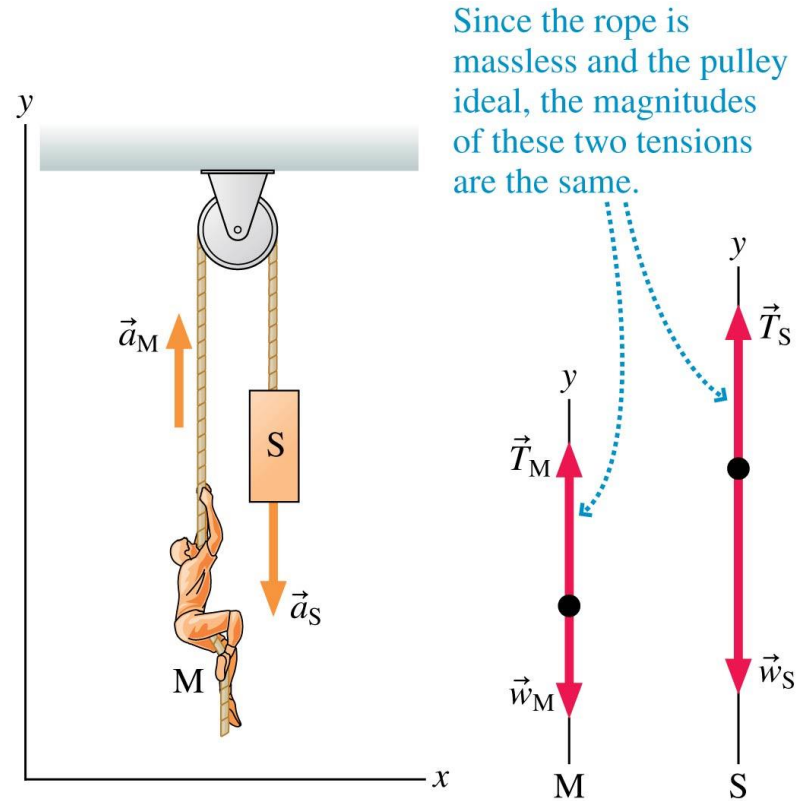

Example 5.18 Lifting a stage set (cont.)

PREPARE FIGURE 5.33 shows the visual overview. The objects of interest are the stagehand M and the set S, for which we've drawn separate

free-body diagrams. Assume a massless rope and a massless, frictionless pulley. Tension forces \vec{T}_S and \vec{T}_M are due to a massless rope going over an ideal pulley, so their magnitudes are the same.

Known
$m_M = 100 \text{ kg}$
$m_S = 200 \text{ kg}$
Find
a_{My}

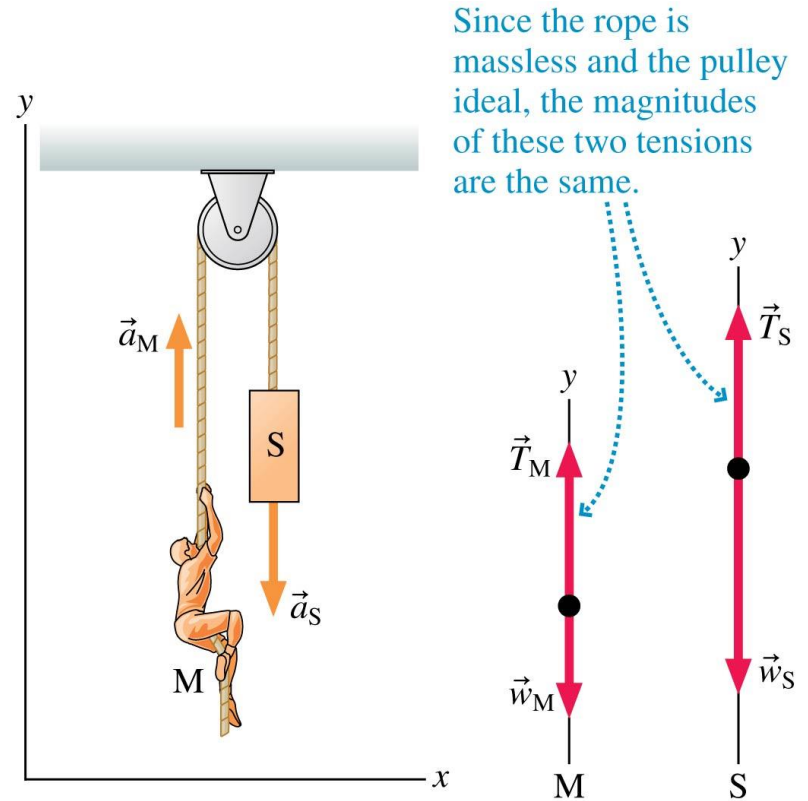

Since the rope is massless and the pulley ideal, the magnitudes of these two tensions are the same.

Example 5.18 Lifting a stage set (cont.)

SOLVE From the two free-body diagrams, we can write Newton's second law in component form. For the man we have

$$\Sigma F_{My} = T_M - w_M = T_M - m_M g = m_M a_{My}$$

For the set we have

$$\Sigma F_{Sy} = T_S - w_S = T_S - m_S g = m_S a_{Sy}$$

Since the rope is massless and the pulley ideal, the magnitudes of these two tensions are the same.

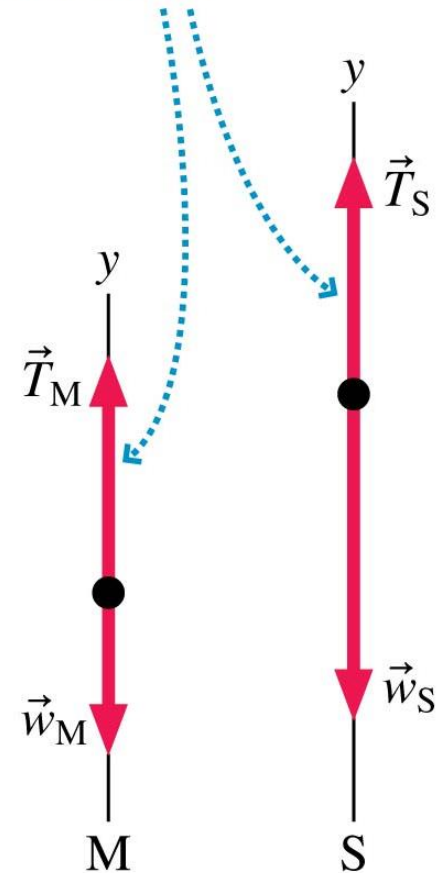

Example 5.18 Lifting a stage set (cont.)

Only the y -equations are needed. Because the stagehand and the set are connected by a rope, the upward distance traveled by one is the *same* as the downward distance traveled by the other. Thus the *magnitudes* of their accelerations must be the same, but, as Figure 5.33 shows, their *directions* are opposite.

Since the rope is massless and the pulley ideal, the magnitudes of these two tensions are the same.

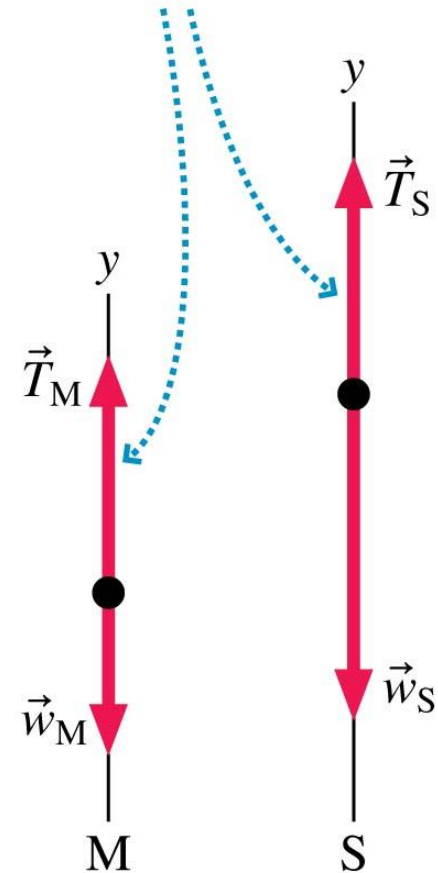

Example 5.18 Lifting a stage set (cont.)

We can express this mathematically as $a_{Sy} = -a_{My}$. We also know that the two tension forces have equal magnitudes, which we'll call T . Inserting this information into the above equations gives

$$T - m_M g = m_M a_{My}$$

$$T - m_S g = -m_S a_{My}$$

Since the rope is massless and the pulley ideal, the magnitudes of these two tensions are the same.

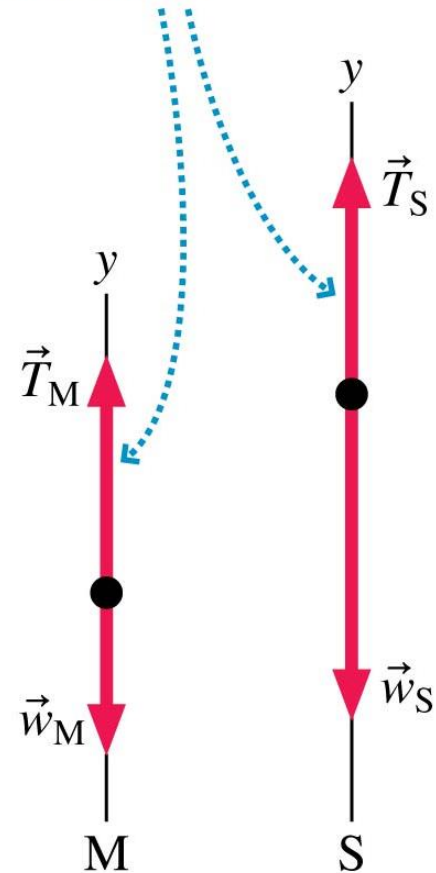

Example 5.18 Lifting a stage set (cont.)

These are simultaneous equations in the two unknowns T and a_{My} . We can solve for T in the first equation to get

$$T = m_M a_{My} + m_M g$$

Inserting this value of T into the second equation then gives

$$m_M a_{My} + m_M g - m_S g = -m_S a_{My}$$

which we can rewrite as

$$(m_S - m_M)g = (m_S + m_M)a_{My}$$

Since the rope is massless and the pulley ideal, the magnitudes of these two tensions are the same.

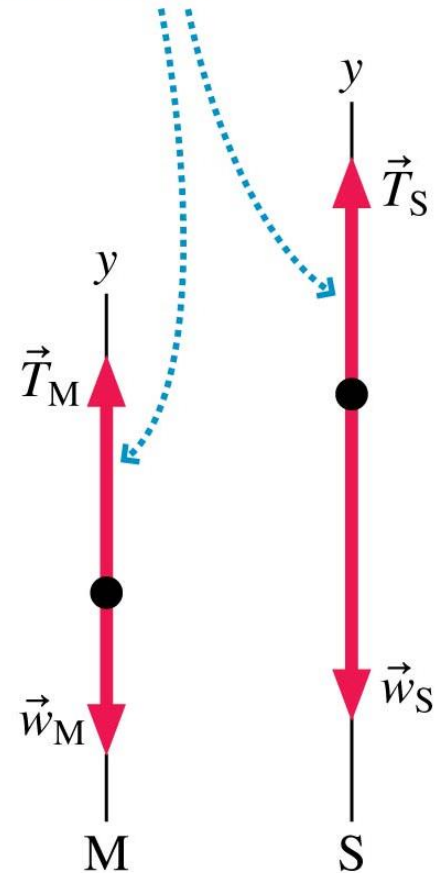

Example 5.18 Lifting a stage set (cont.)

Finally, we can solve for the hapless stagehand's acceleration:

$$a_{My} = \frac{m_S - m_M}{m_S + m_M} g = \left(\frac{100 \text{ kg}}{300 \text{ kg}} \right) \times 9.80 \text{ m/s}^2 = 3.3 \text{ m/s}^2$$

This is also the acceleration with which the set falls. If the rope's tension was needed, we could now find it from

$$T = m_M a_{My} + m_M g.$$

ASSESS If the stagehand weren't holding on, the set would fall with free-fall acceleration g . The stagehand acts as a *counterweight* to reduce the acceleration.

Summary: General Strategy

Equilibrium Problems

Object at rest or moving at constant velocity.

PREPARE Make simplifying assumptions.

- Check that the object is either at rest or moving with constant velocity ($\vec{a} = \vec{0}$).
- Identify forces and show them on a free-body diagram.

SOLVE Use Newton's second law in component form:

$$\sum F_x = ma_x = 0$$

$$\sum F_y = ma_y = 0$$

“Read” the components from the free-body diagram.

ASSESS Is your result reasonable?

Summary: General Strategy

Dynamics Problems

Object accelerating.

PREPARE Make simplifying assumptions.

Make a **visual overview**:

- Sketch a pictorial representation.
- Identify known quantities and what the problem is trying to find.
- Identify all forces and show them on a free-body diagram.

SOLVE Use Newton's second law in component form:

$$\sum F_x = ma_x \quad \text{and} \quad \sum F_y = ma_y$$

“Read” the components of the vectors from the free-body diagram.
If needed, use kinematics to find positions and velocities.

ASSESS Is your result reasonable?

Summary: Important Concepts

Specific information about three important forces:

Weight $\vec{w} = (mg, \text{downward})$

Friction $\vec{f}_s = (0 \text{ to } \mu_s n, \text{direction as necessary to prevent motion})$

$\vec{f}_k = (\mu_k n, \text{direction opposite the motion})$

$\vec{f}_r = (\mu_r n, \text{direction opposite the motion})$

Drag $\vec{D} = (\frac{1}{4}\rho Av^2, \text{direction opposite the motion for motion in air})$

Text: p. 152

Summary: Important Concepts

Newton's laws are vector expressions. You must write them out by

components:

$$(F_{\text{net}})_x = \sum F_x = ma_x$$

$$(F_{\text{net}})_y = \sum F_y = ma_y$$

For equilibrium problems,
 $a_x = 0$ and $a_y = 0$.

Text: p. 152

Summary: Important Concepts

Objects in Contact

When two objects interact, you need to draw two separate free-body diagrams.

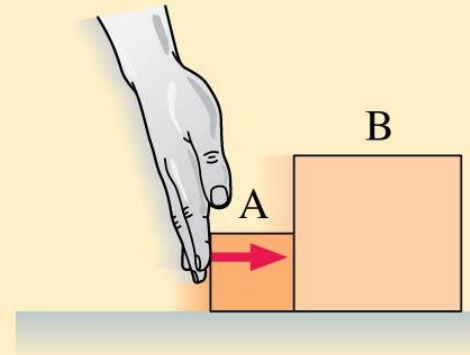

The action/reaction pairs of forces have equal magnitude and opposite directions.

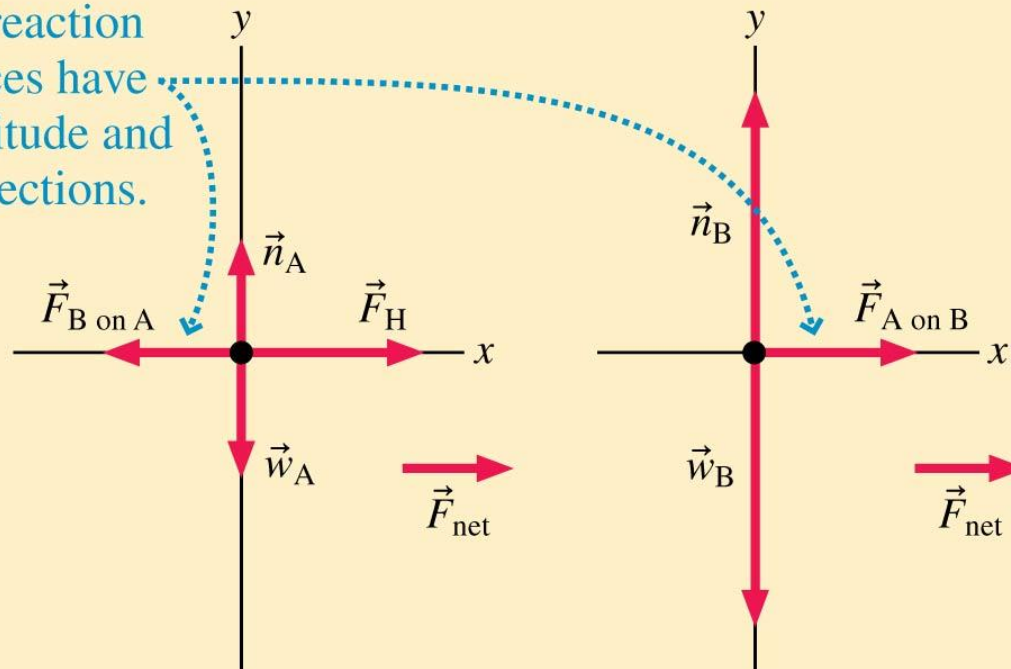

Text: p. 152

Slide 5-172

Summary: Applications

Apparent weight is the magnitude of the contact force supporting an object. It is what a scale would read, and it is your sensation of weight.

Apparent weight equals your true weight $w = mg$ only when the vertical acceleration is zero.

Text: p. 152

Summary: Applications

A falling object reaches **terminal speed** when the drag force exactly balances the weight force: $\vec{a} = \vec{0}$.



Text: p. 152

Summary: Applications

Strings and pulleys

- A string or rope pulls what it's connected to with a force equal to its tension.
- The tension in a rope is equal to the force pulling on the rope.
- The tension in a massless rope is the same at all points in the rope.
- Tension does not change when a rope passes over a massless, frictionless pulley.

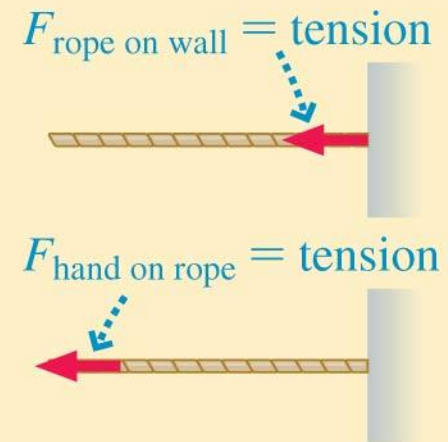

Text: p. 152

Summary

GENERAL STRATEGY

All examples in this chapter follow a three-part strategy. You'll become a better problem solver if you adhere to it as you do the homework problems. The *Dynamics Worksheets* in the *Student Workbook* will help you structure your work in this way.

Equilibrium Problems

Object at rest or moving at constant velocity.

PREPARE Make simplifying assumptions.

- Check that the object is either at rest or moving with constant velocity ($\vec{a} = \vec{0}$).
- Identify forces and show them on a free-body diagram.

SOLVE Use Newton's second law in component form:

$$\sum F_x = ma_x = 0$$

$$\sum F_y = ma_y = 0$$

“Read” the components from the free-body diagram.

ASSESS Is your result reasonable?

Dynamics Problems

Object accelerating.

PREPARE Make simplifying assumptions.

Make a **visual overview**:

- Sketch a pictorial representation.
- Identify known quantities and what the problem is trying to find.
- Identify all forces and show them on a free-body diagram.

SOLVE Use Newton's second law in component form:

$$\sum F_x = ma_x \quad \text{and} \quad \sum F_y = ma_y$$

“Read” the components of the vectors from the free-body diagram. If needed, use kinematics to find positions and velocities.

ASSESS Is your result reasonable?

Text: p. 152

Summary

IMPORTANT CONCEPTS

Specific information about three important forces:

Weight $\vec{w} = (mg, \text{downward})$

Friction $\vec{f}_s = (0 \text{ to } \mu_s n, \text{direction as necessary to prevent motion})$

$\vec{f}_k = (\mu_k n, \text{direction opposite the motion})$

$\vec{f}_r = (\mu_r n, \text{direction opposite the motion})$

Drag $\vec{D} = \frac{1}{4}\rho A v^2$, direction opposite the motion for motion in air

Newton's laws are vector expressions. You must write them out by

components:

$$(F_{\text{net}})_x = \sum F_x = ma_x$$

$$(F_{\text{net}})_y = \sum F_y = ma_y$$

For equilibrium problems, $a_x = 0$ and $a_y = 0$.

Objects in Contact

When two objects interact, you need to draw two separate free-body diagrams.

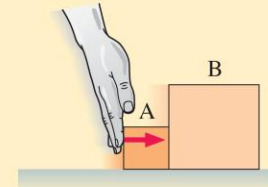

The action/reaction pairs of forces have equal magnitude and opposite directions.

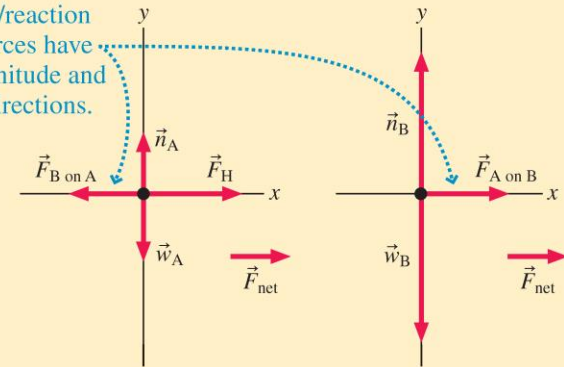

Text: p. 152

Summary

APPLICATIONS

Apparent weight is the magnitude of the contact force supporting an object. It is what a scale would read, and it is your sensation of weight.

Apparent weight equals your true weight $w = mg$ only when the vertical acceleration is zero.

A falling object reaches **terminal speed** when the drag force exactly balances the weight force: $\vec{a} = \vec{0}$.



Strings and pulleys

- A string or rope pulls what it's connected to with a force equal to its tension.
- The tension in a rope is equal to the force pulling on the rope.
- The tension in a massless rope is the same at all points in the rope.
- Tension does not change when a rope passes over a massless, frictionless pulley.

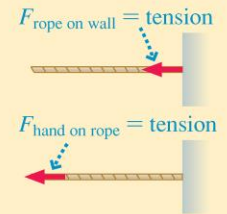

Text: p. 152